

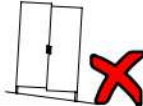

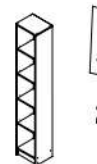

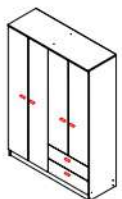

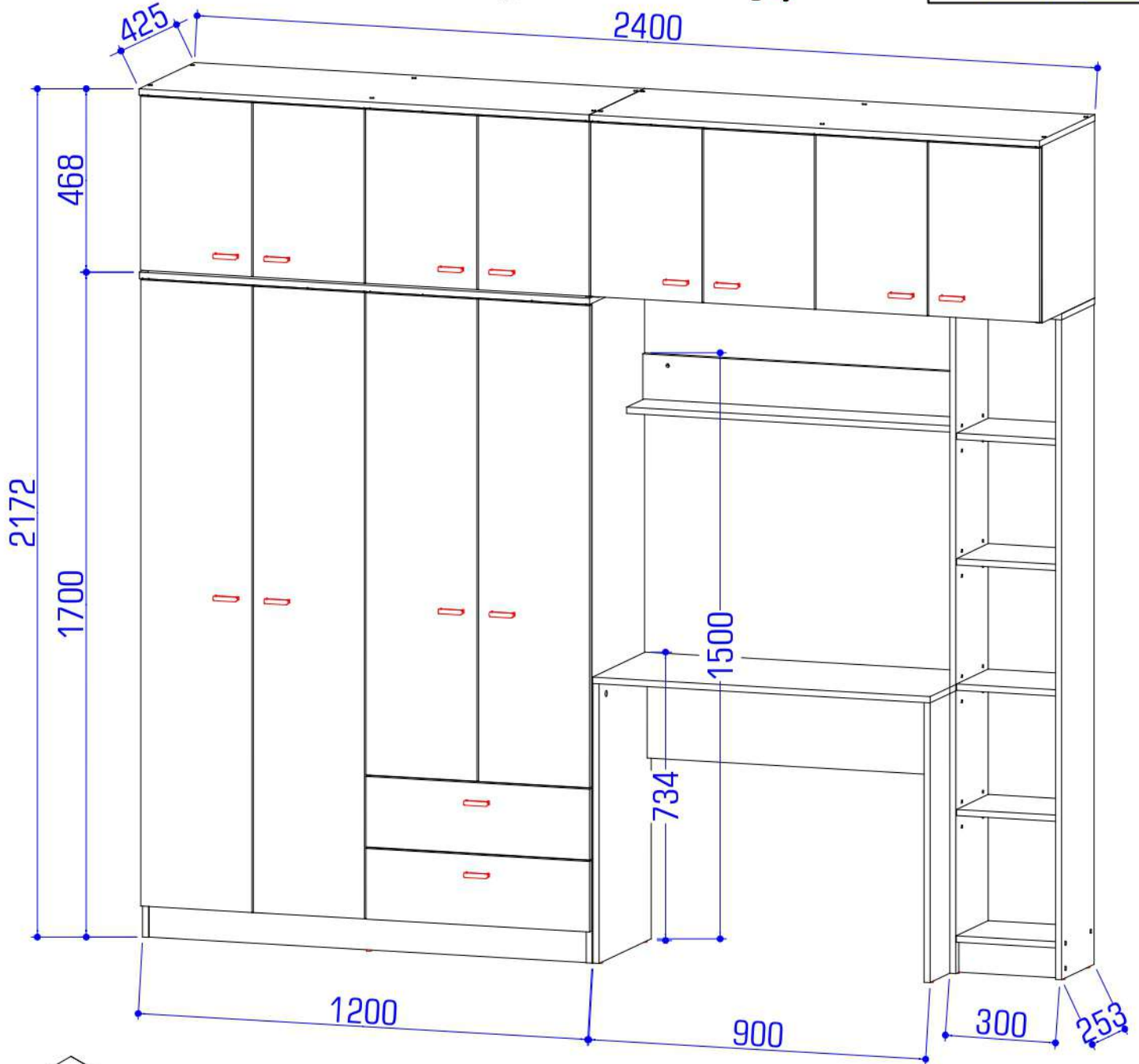

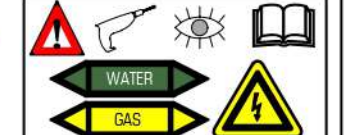
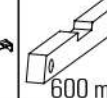
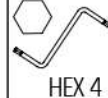
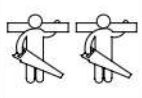

ORBI

Art.-Nr.

419 514
419 515
419 516

	2400	1 /34
	2172	
	425	v0
	[mm]	26-2026



								
D	J	L	N	U	V	I1	Y	I2
2x	4x	4x	4x	4x	4x	6x	5x	2x

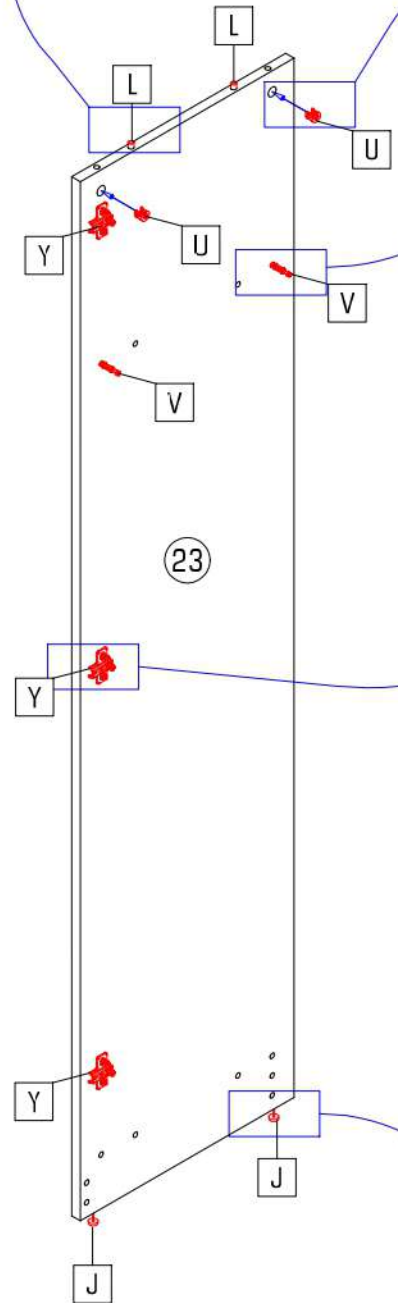
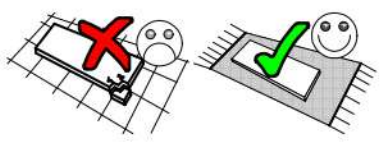
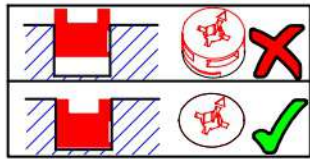
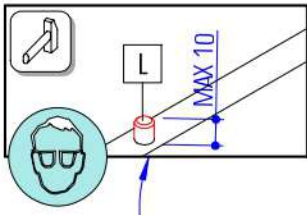



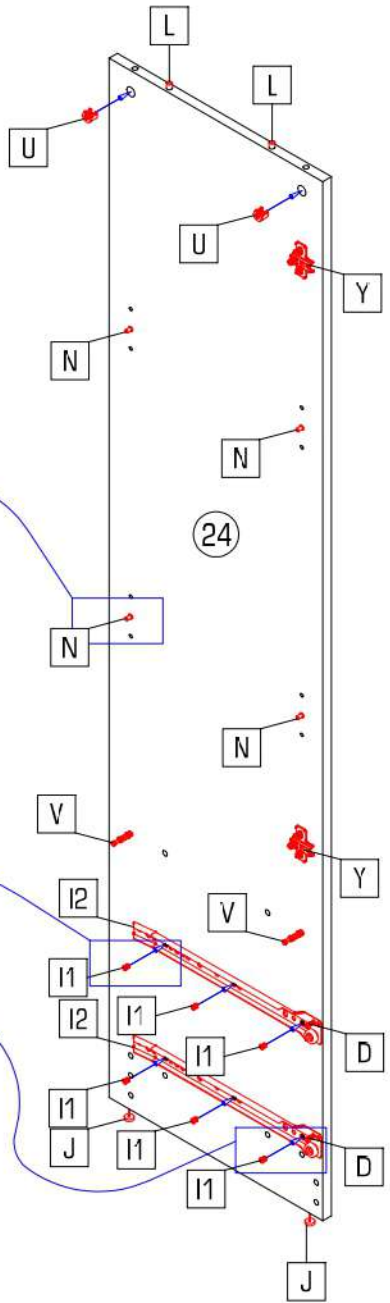
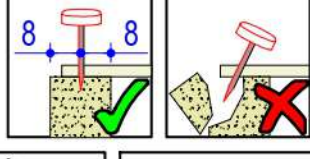
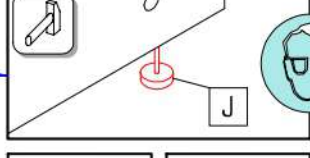
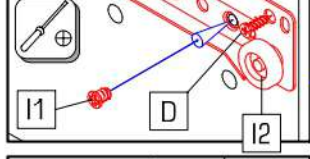
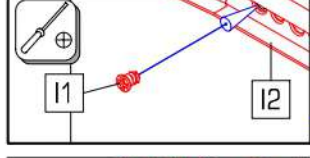
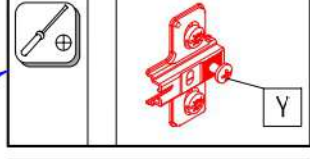
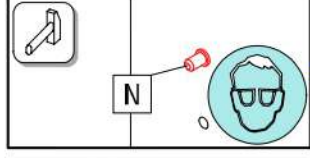
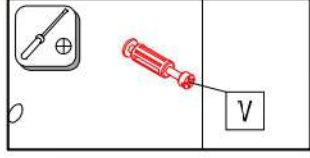
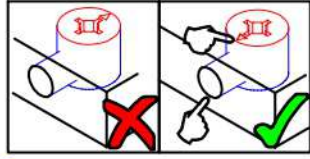
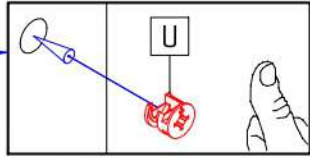

23

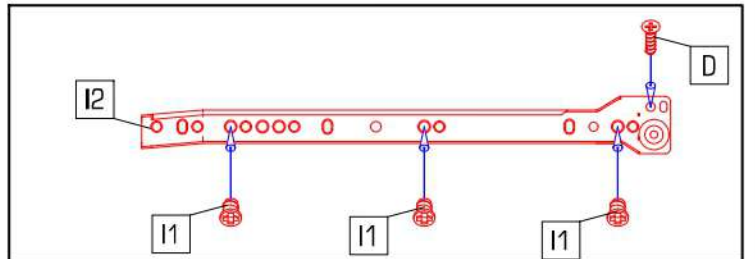
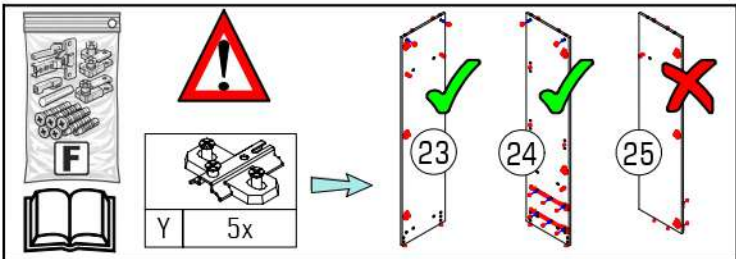

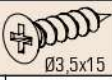

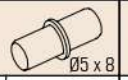
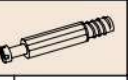

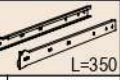

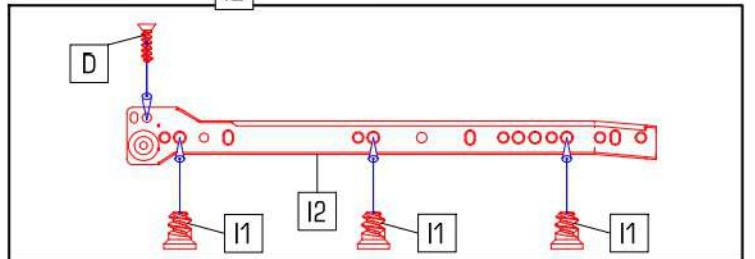
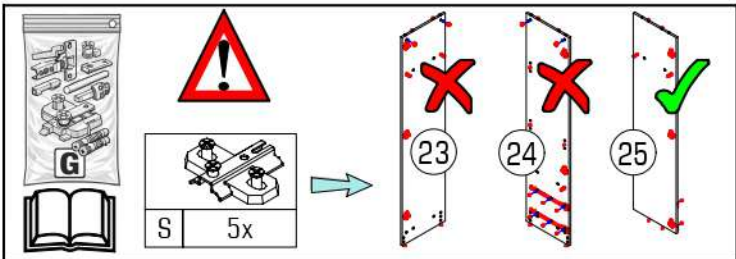
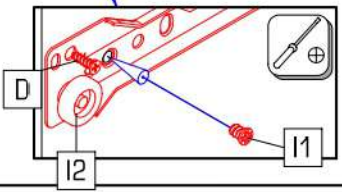
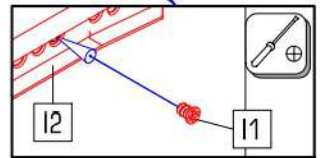
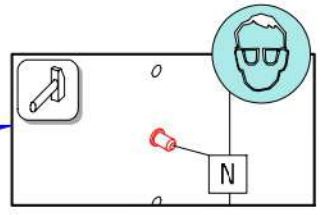
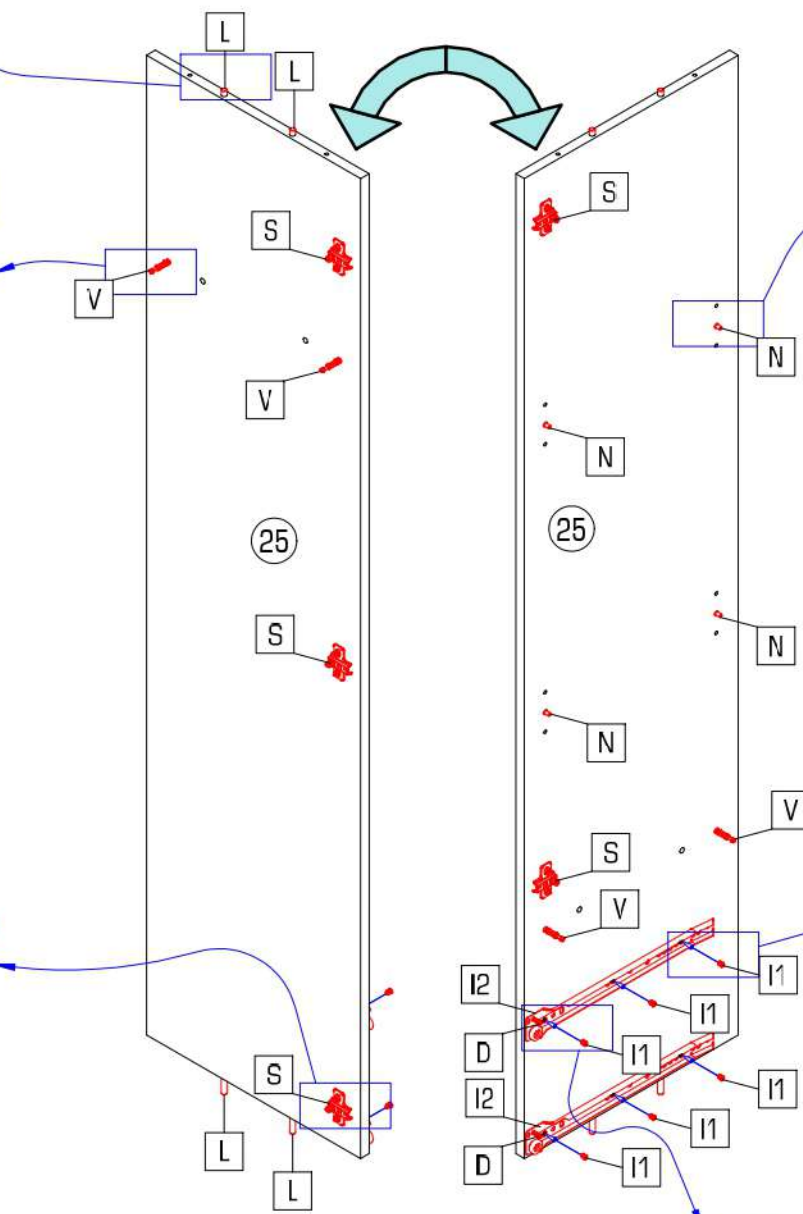
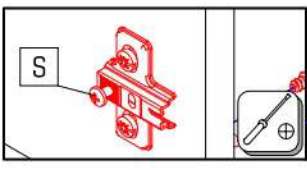
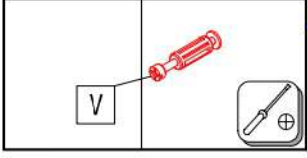
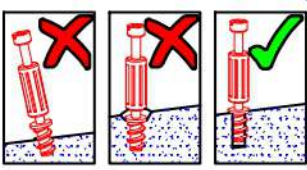
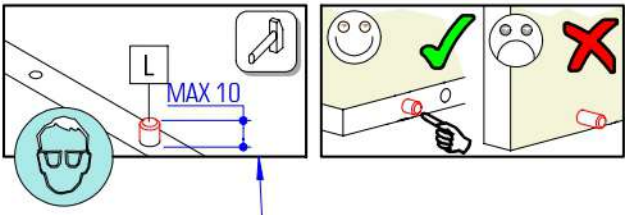
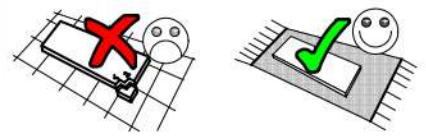
24



						
D	L	N	V	I1	S	I2
2x	4x	4x	4x	6x	5x	2x



					
Ø3,5x16	L=350	Ø15, H=4	Ø8x30	Ø15x13	
E 4x	E2 1x	J 2x	L 20x	U 8x	V 4x

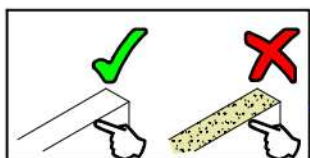
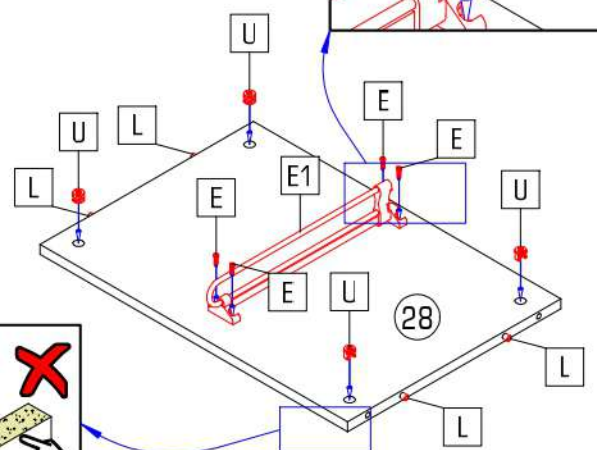
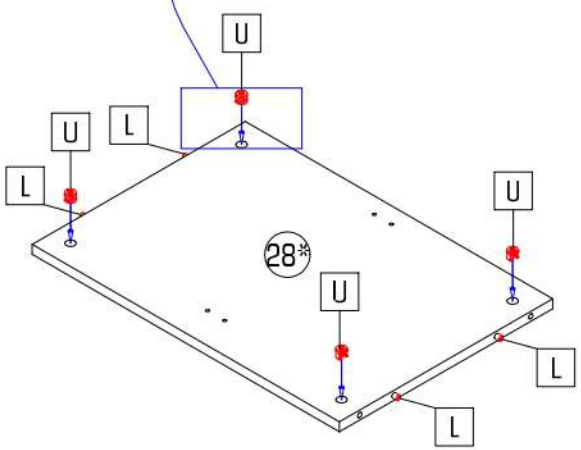
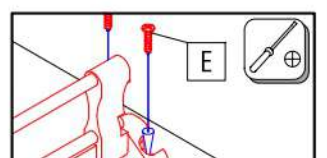
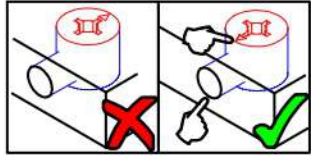
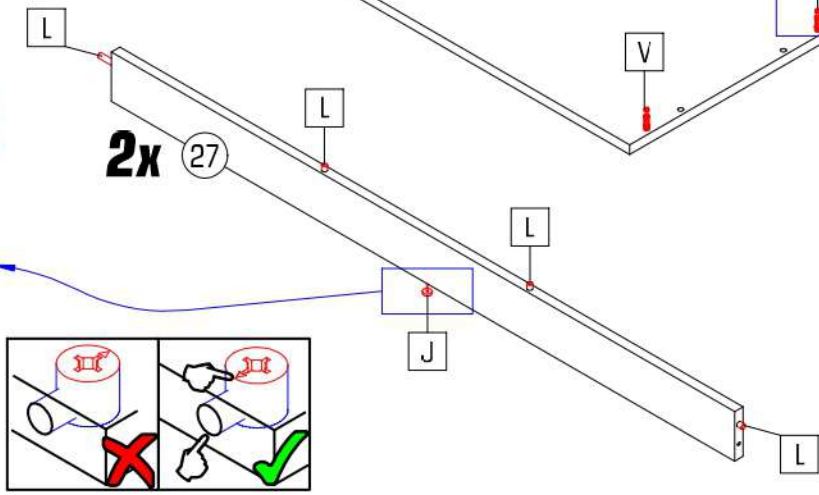
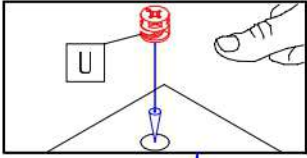
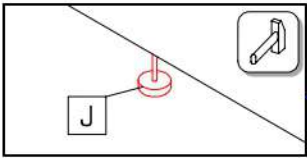
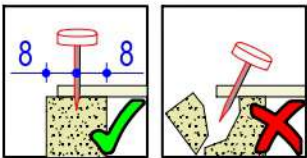
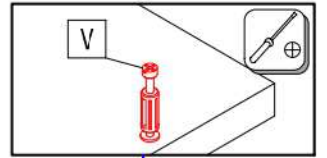
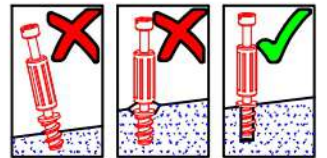
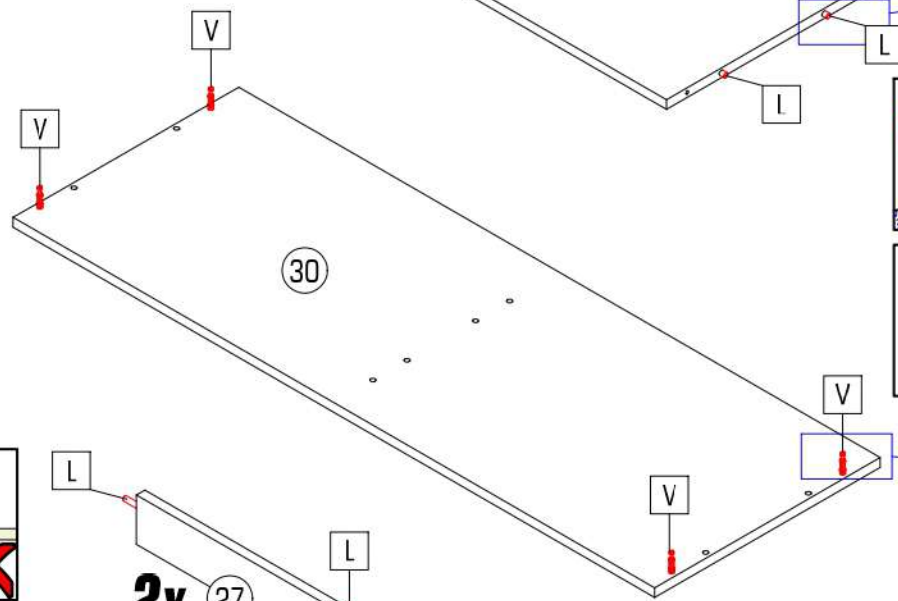
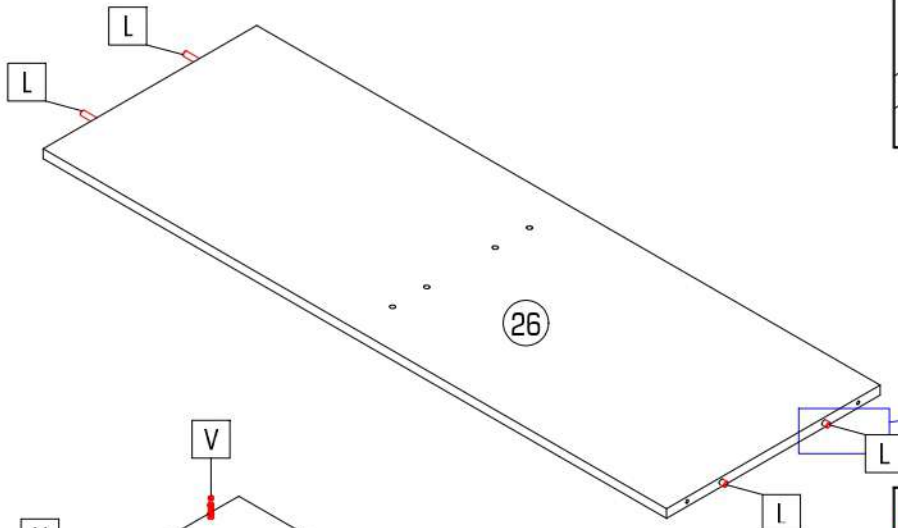
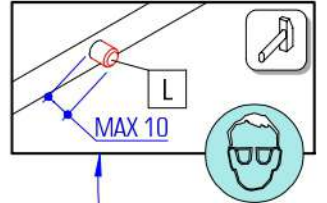

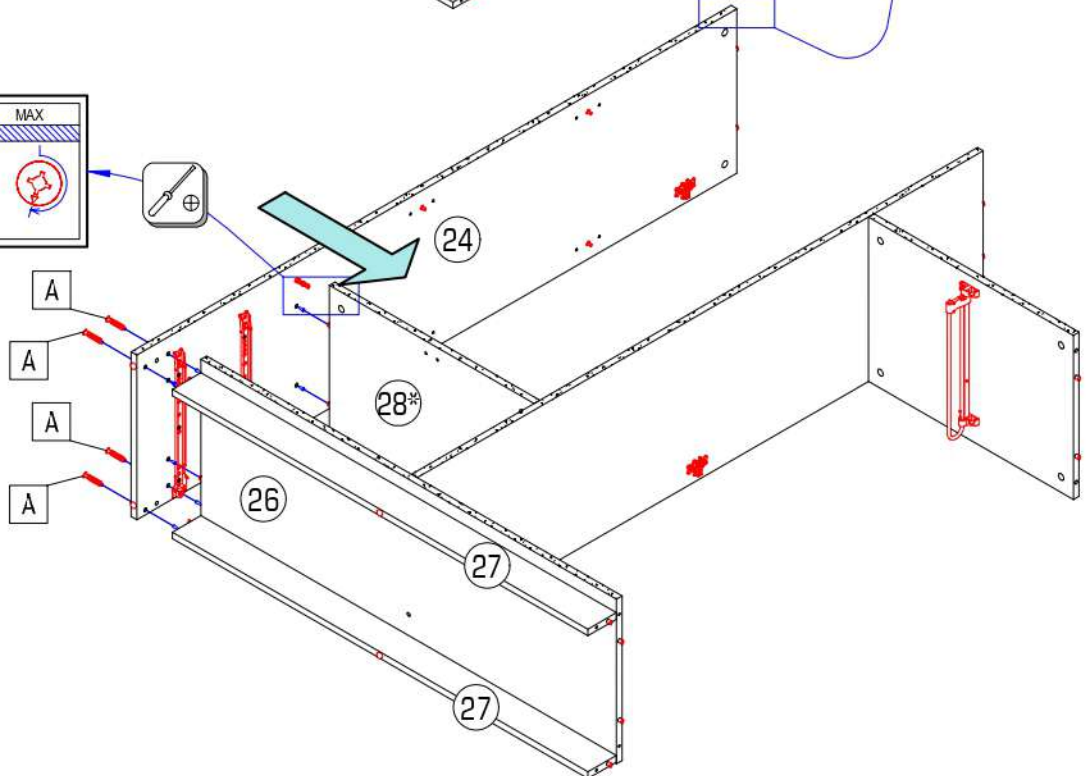
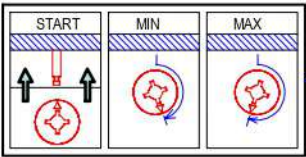
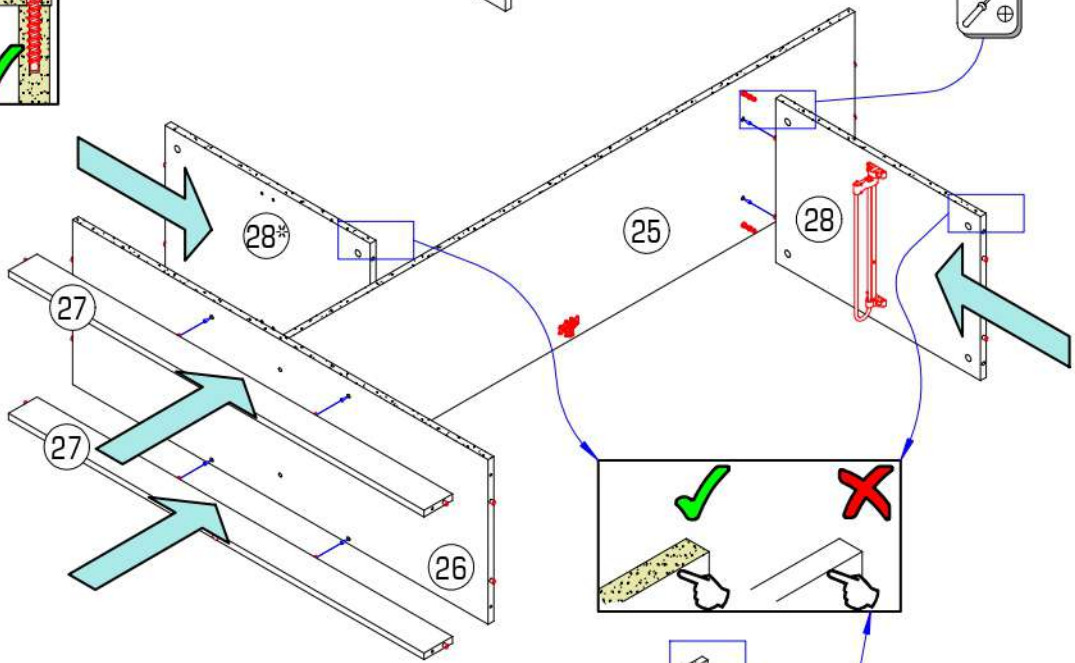
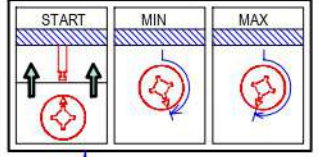
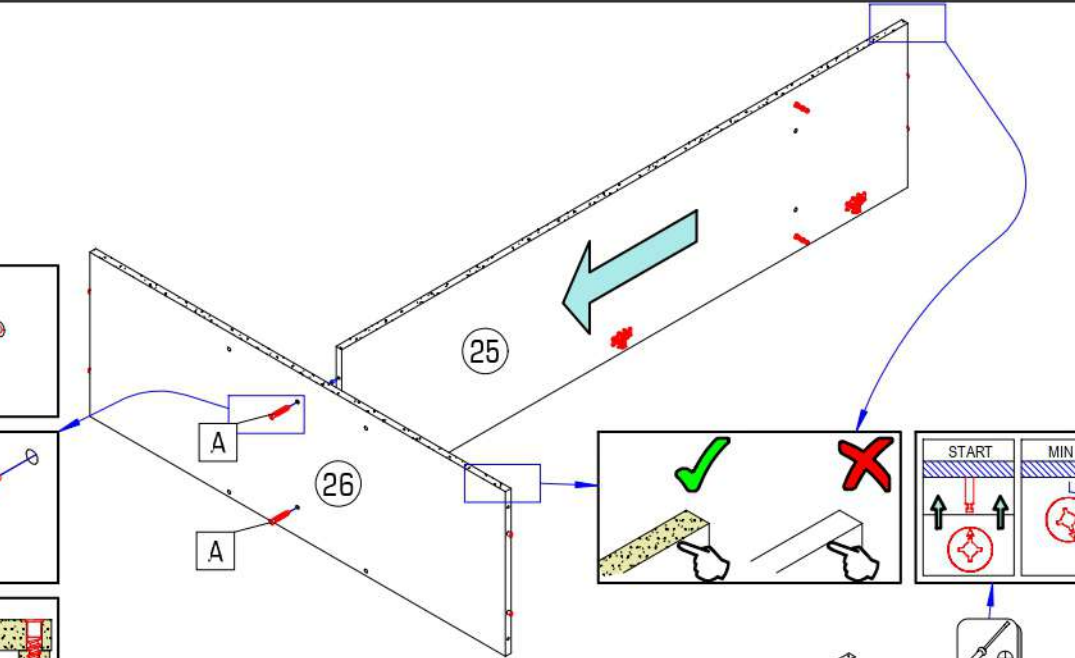
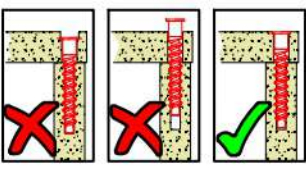
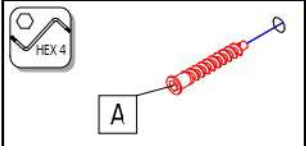
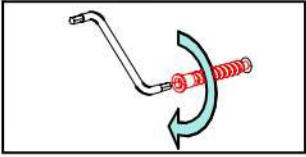
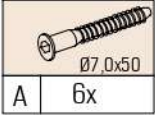

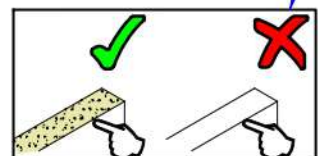
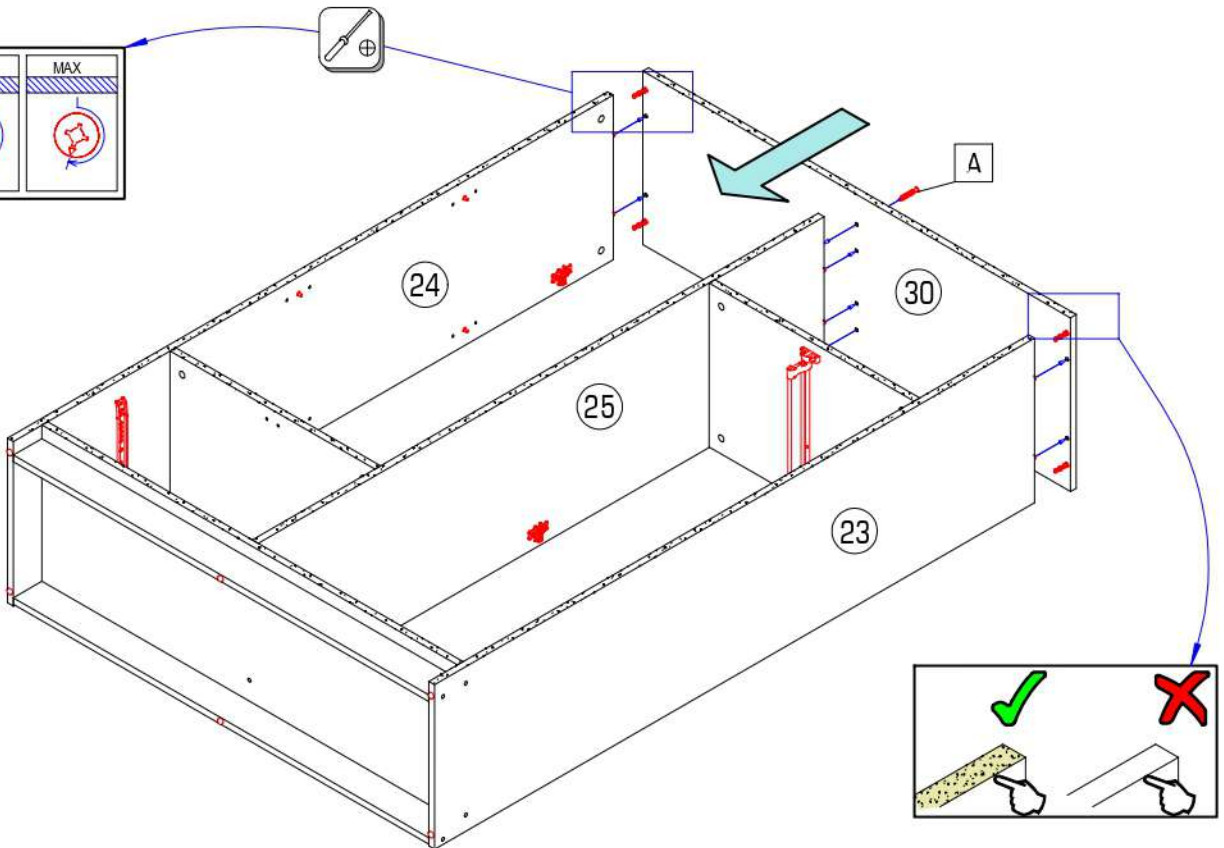
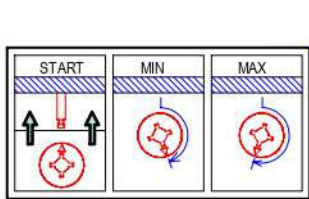
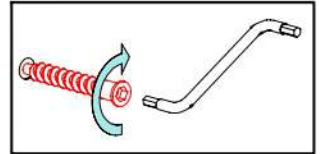
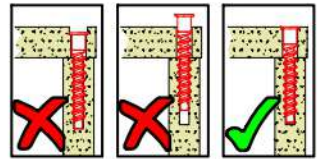
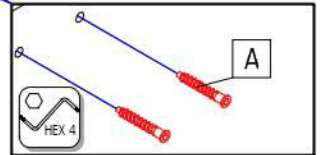
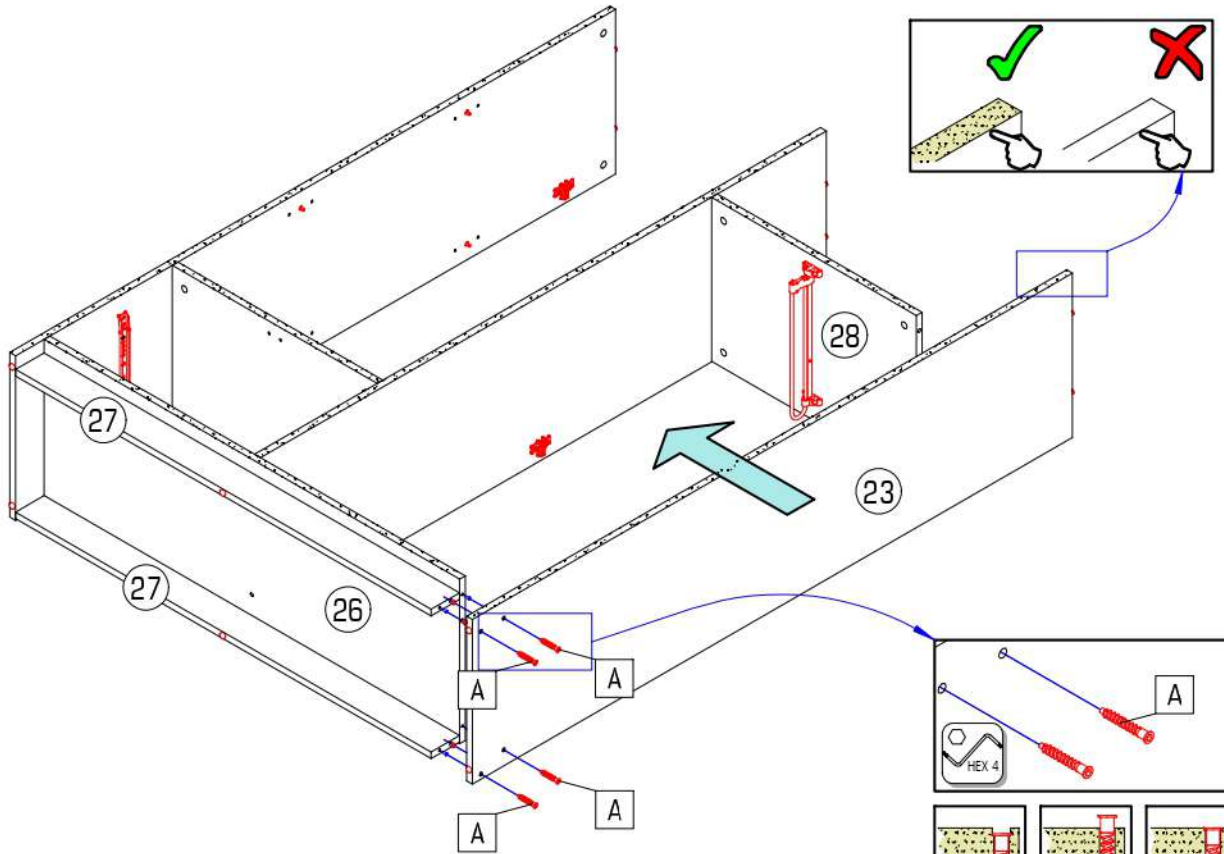
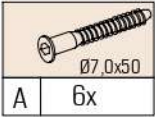

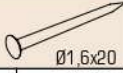
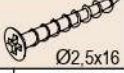
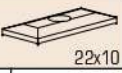

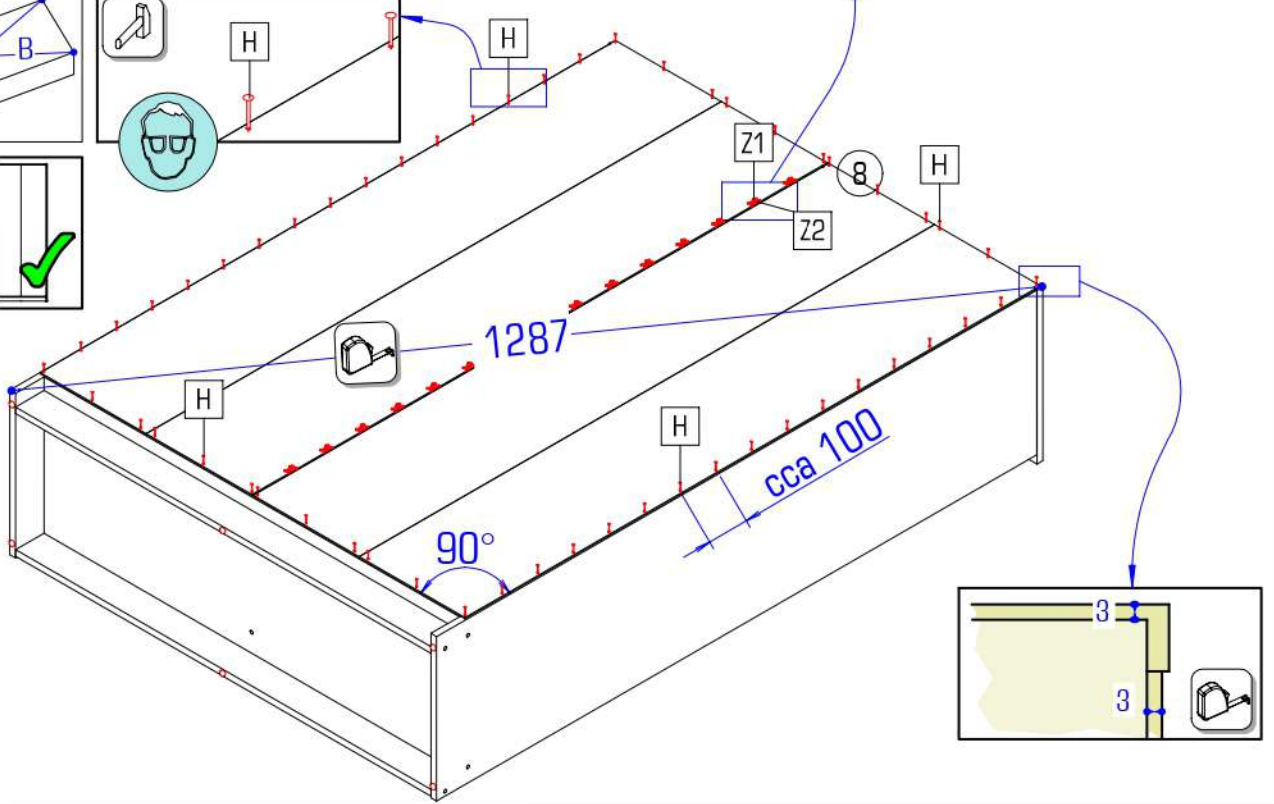
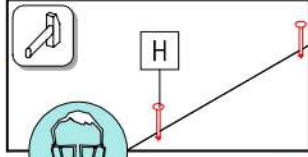
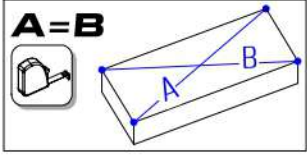
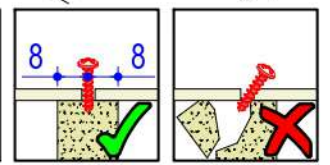
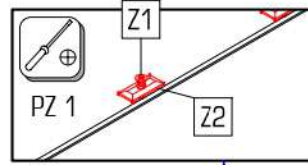
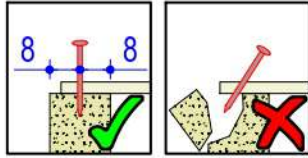
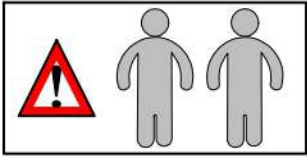





		
Ø1.6x20	Ø2.5x16	22x10
H 54x	Z1 15x	Z2 15x

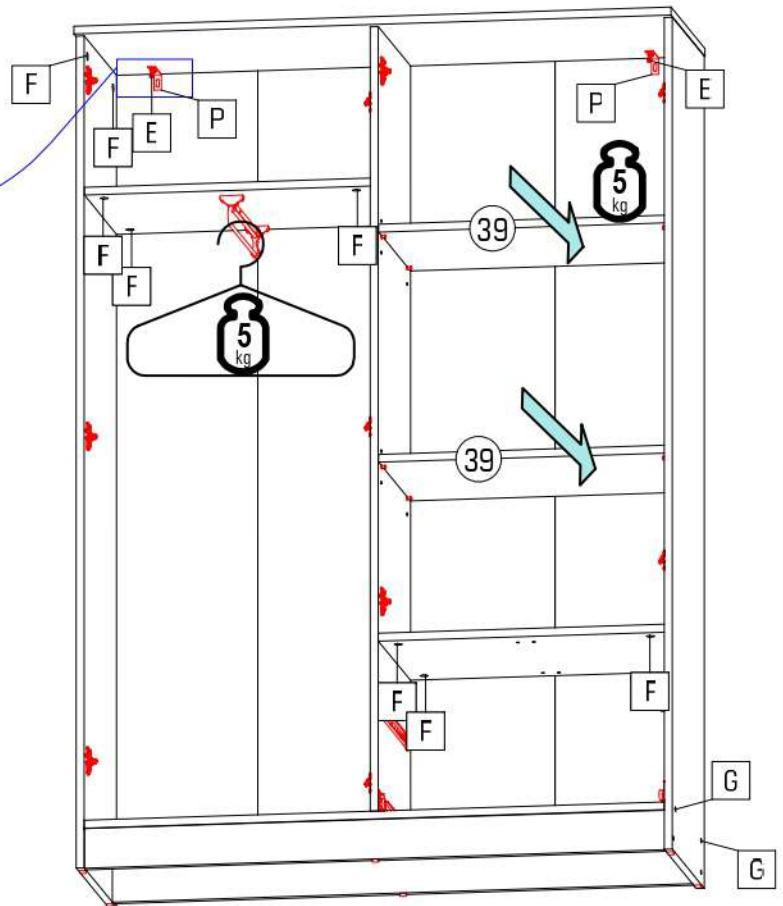
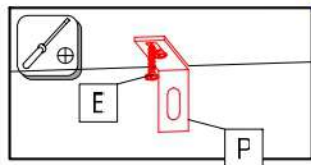

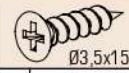
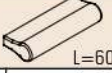

			
Ø3.5x16	76x15x32		
E 4x	P 2x	F 12x	G 10x



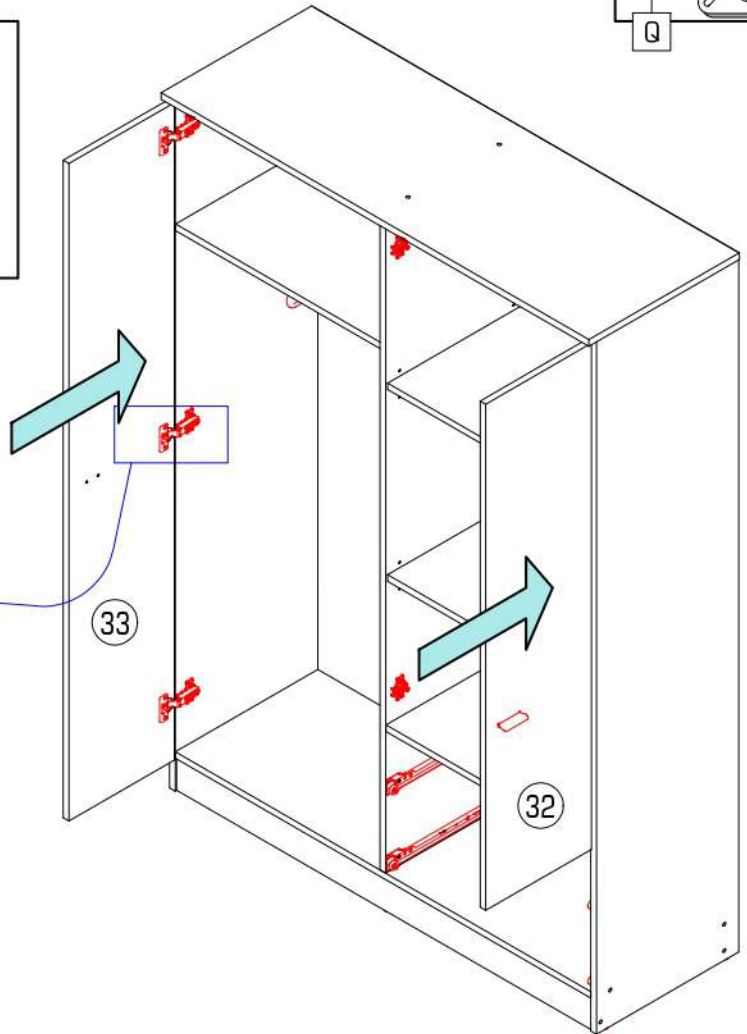
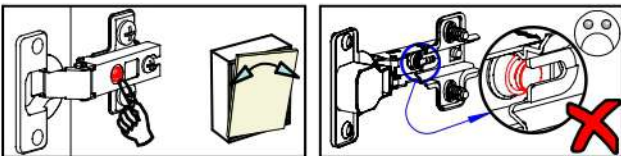
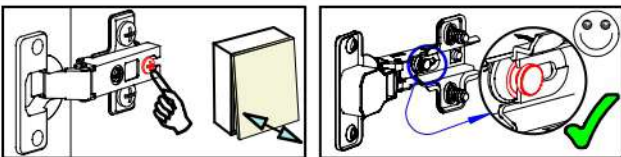
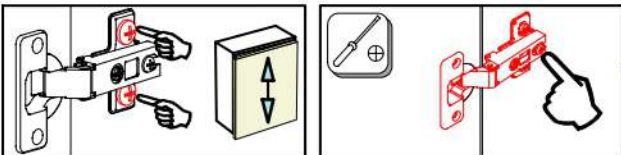
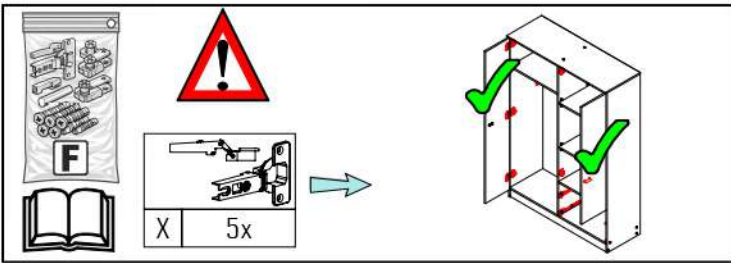
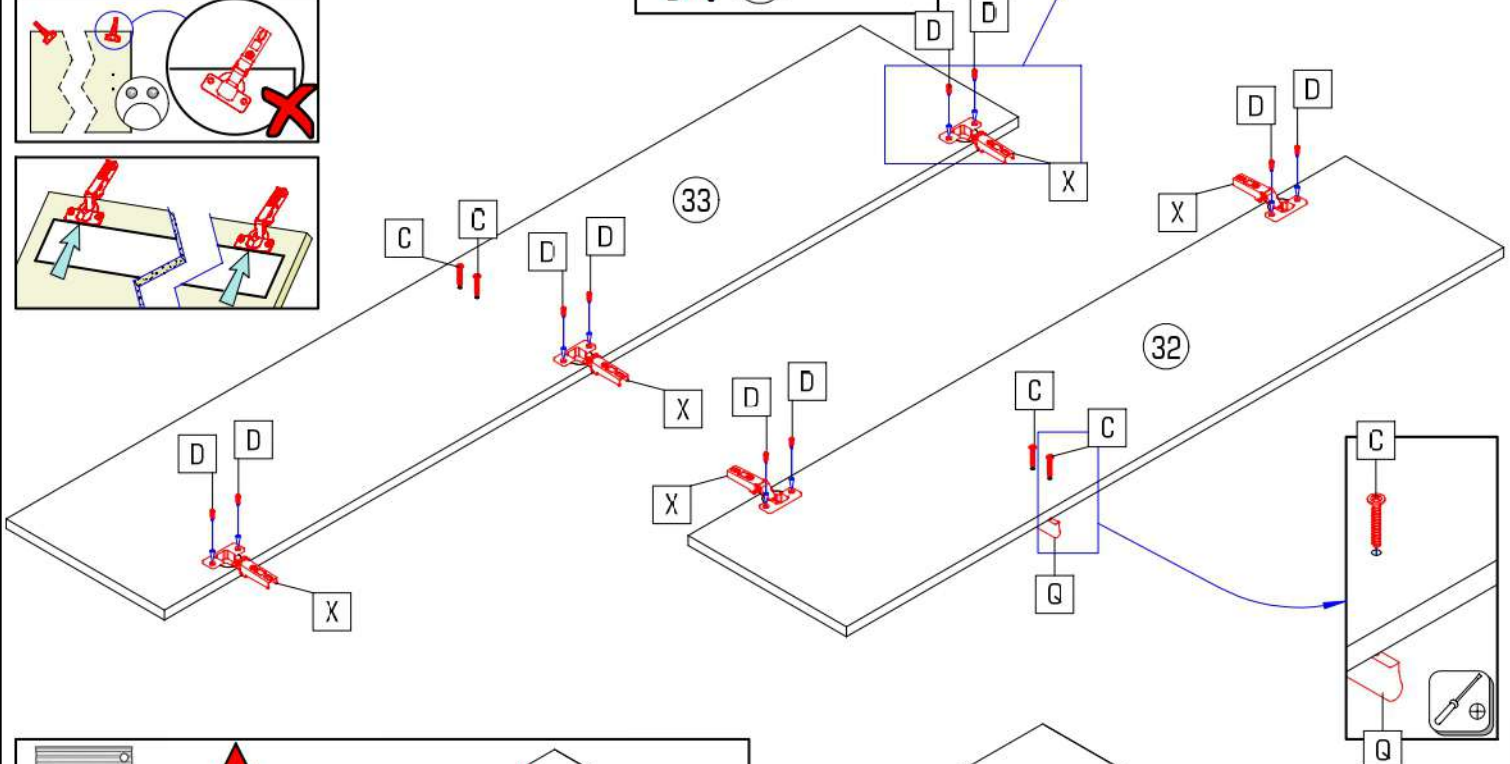
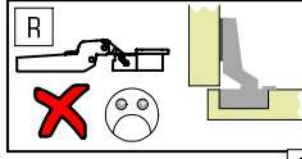
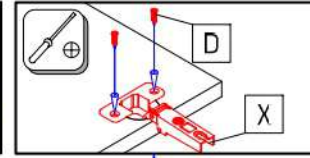
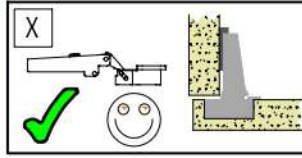
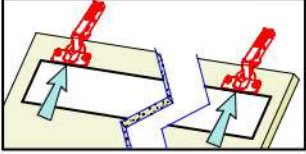
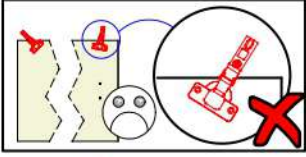
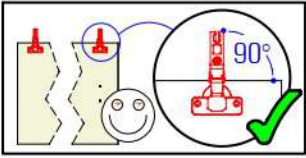

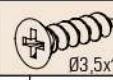
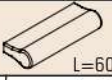

 C 4x	 D 10x	 Q 2x	 X 5x
--	--	---	---

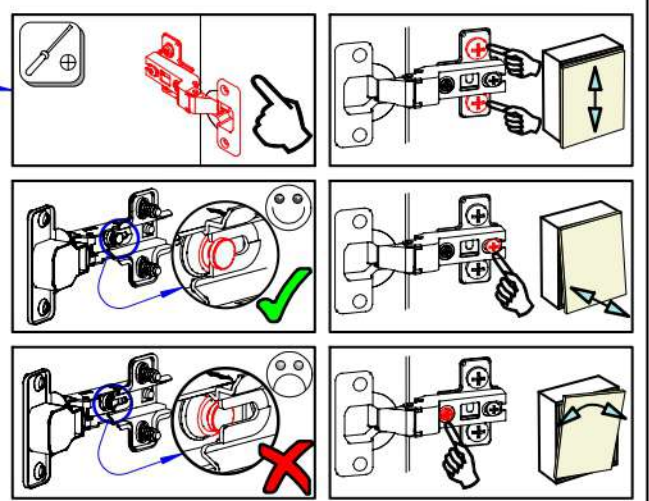
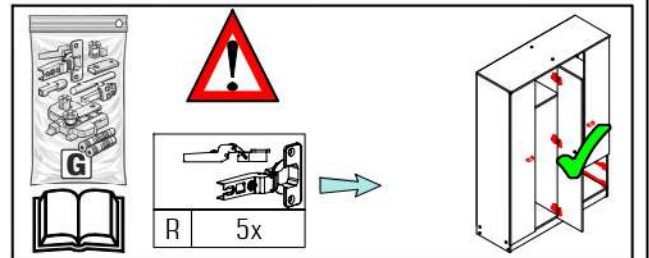
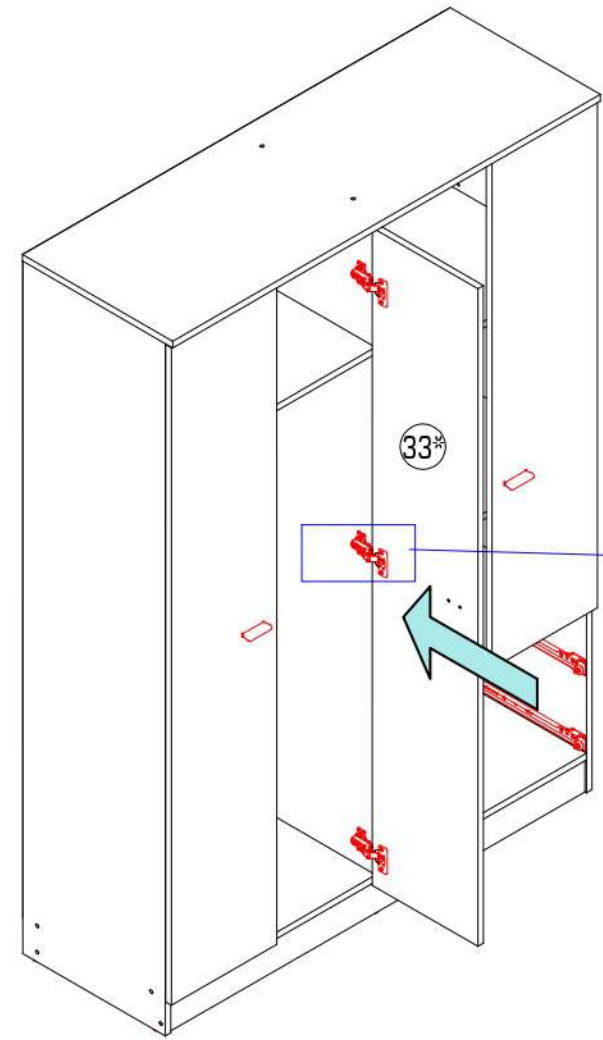
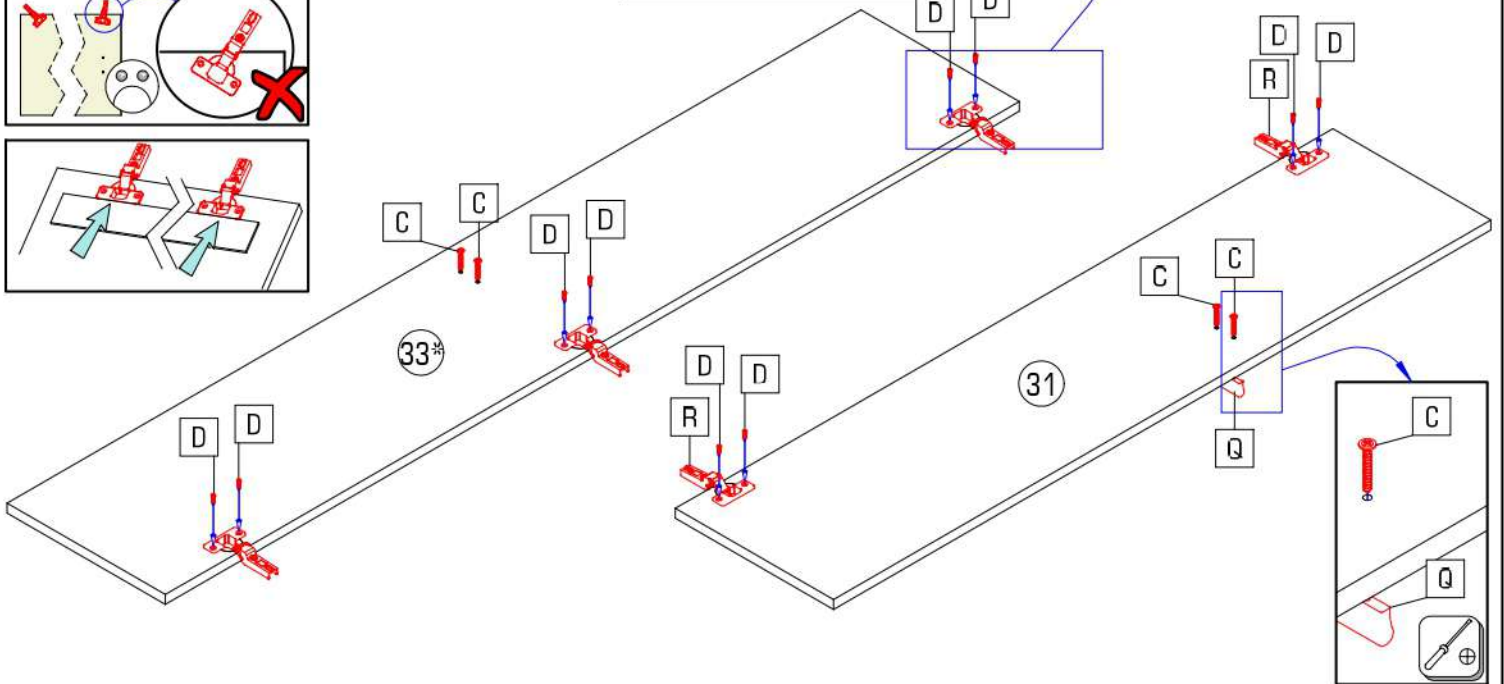
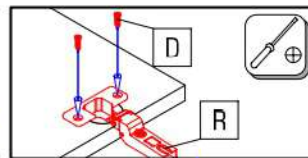
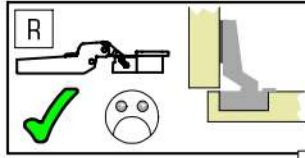
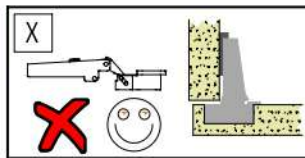
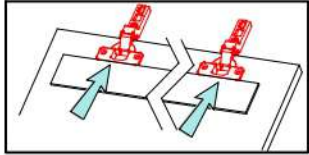
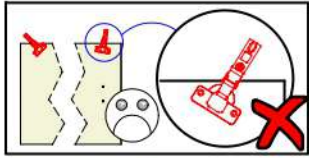
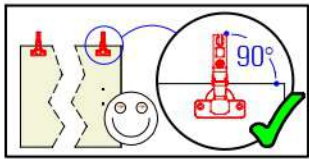

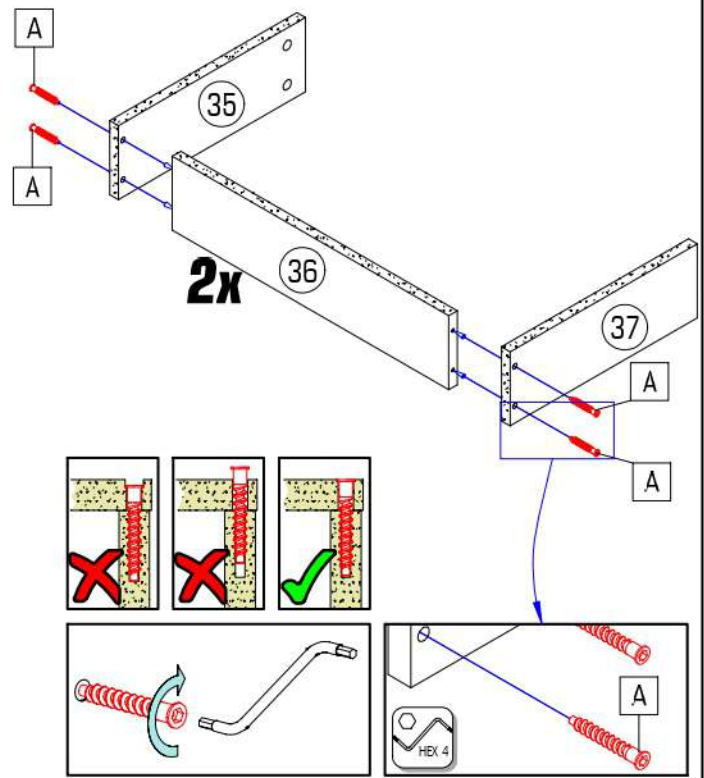
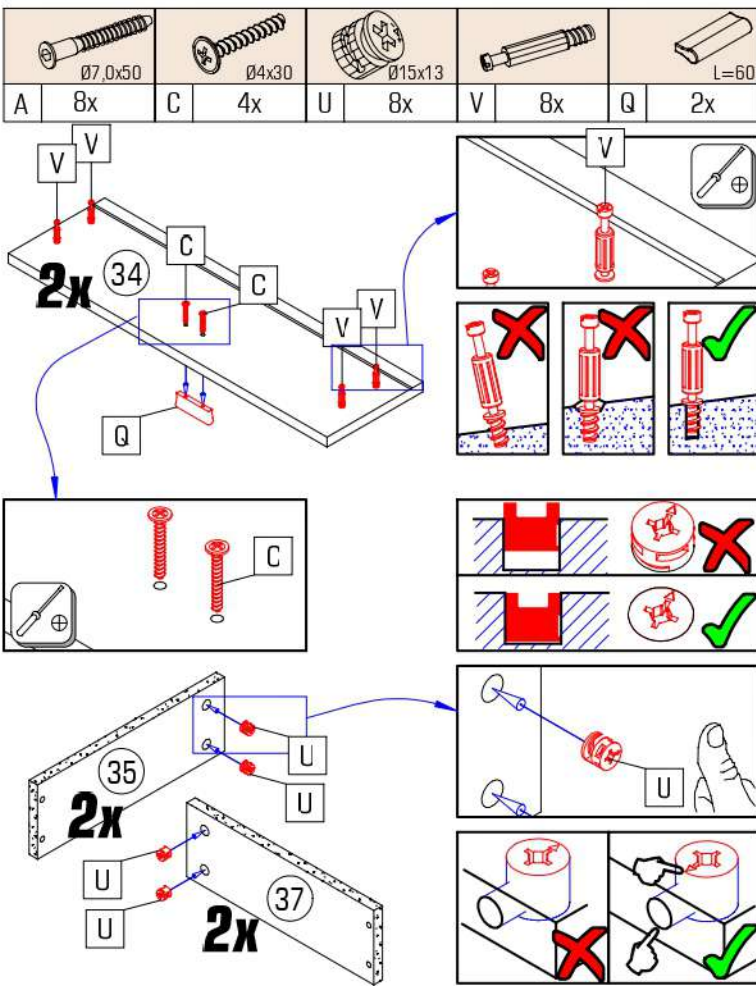
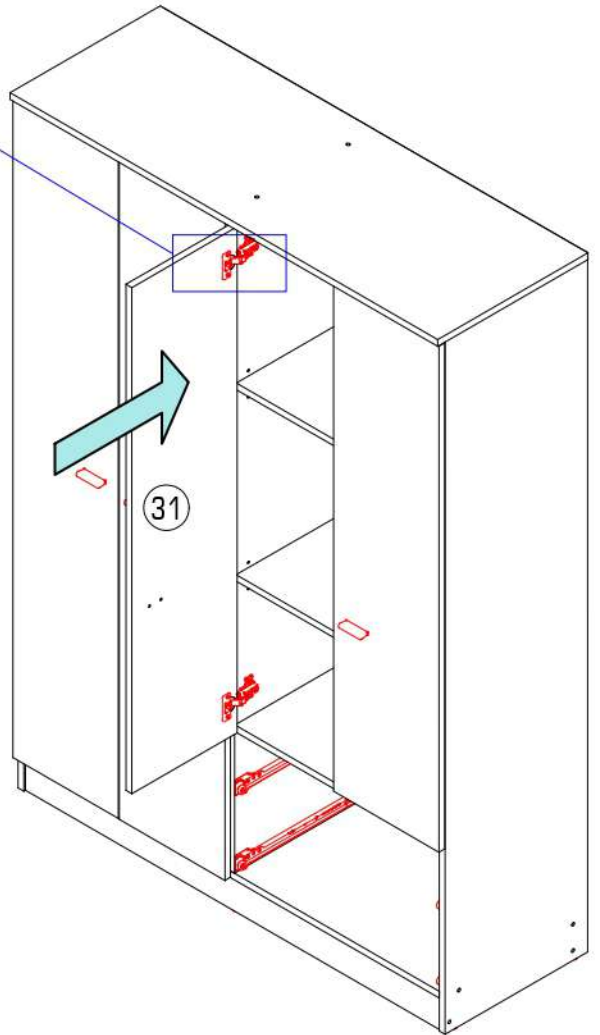
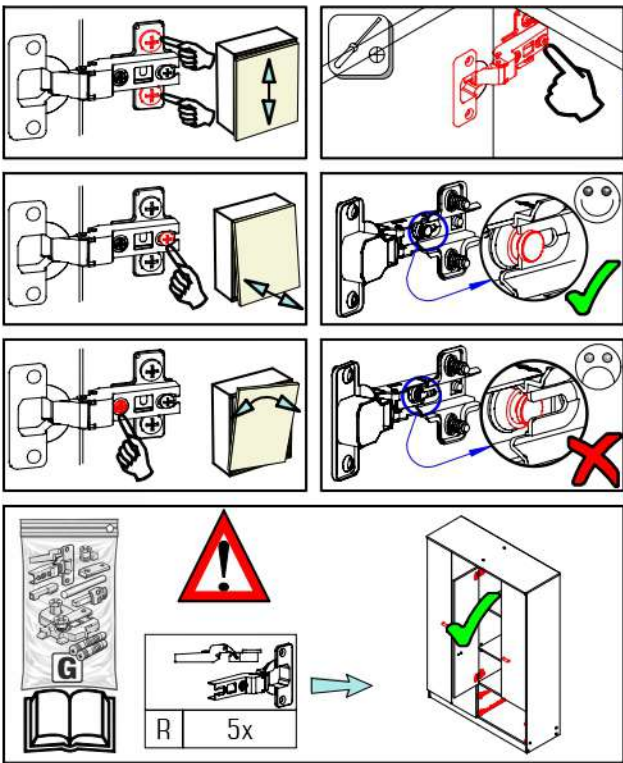
			
C	D	Q	R
4x	10x	2x	5x





		
Ø3,5x16	F2	L=350
E 18x	8x	I3 2x

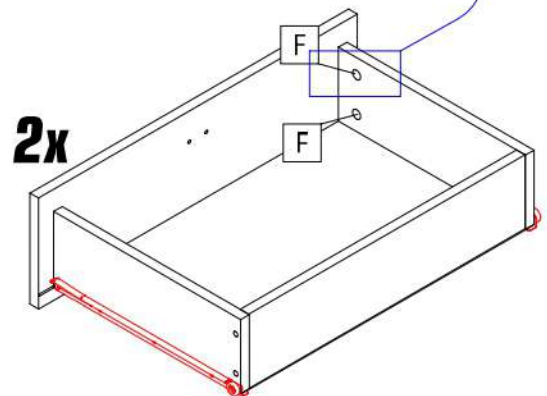
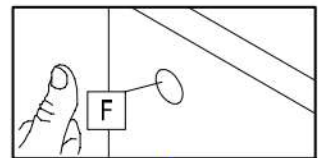
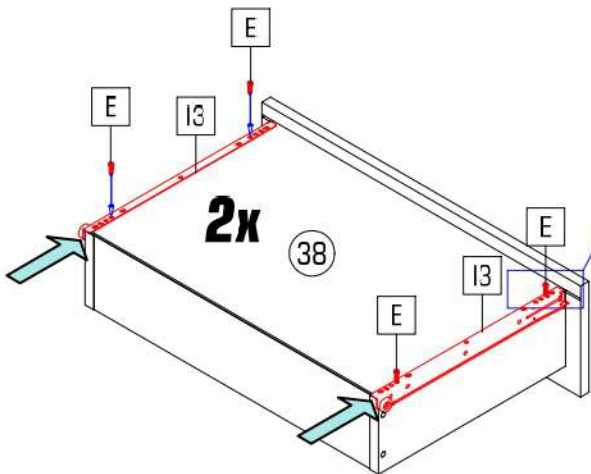
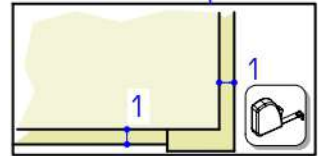
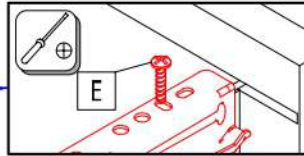
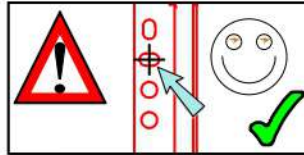
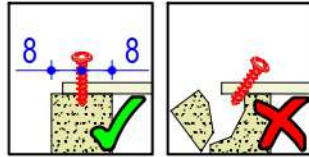
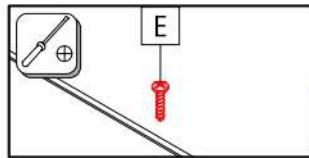
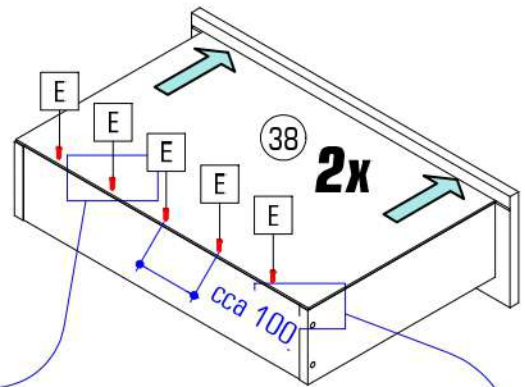
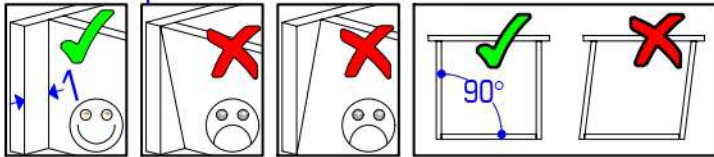
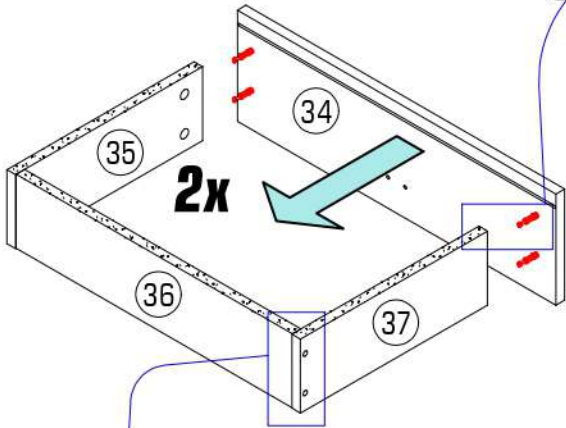
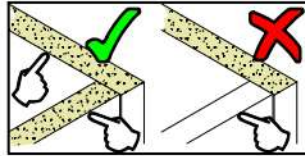
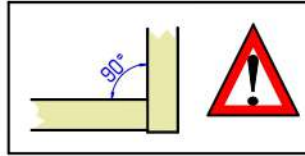
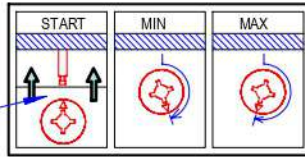

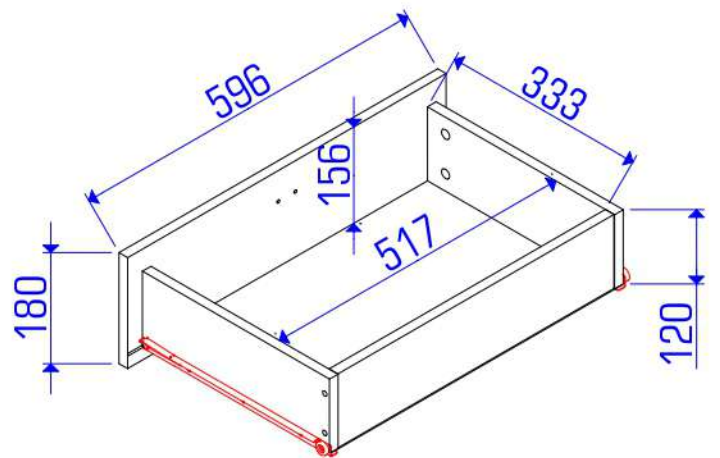
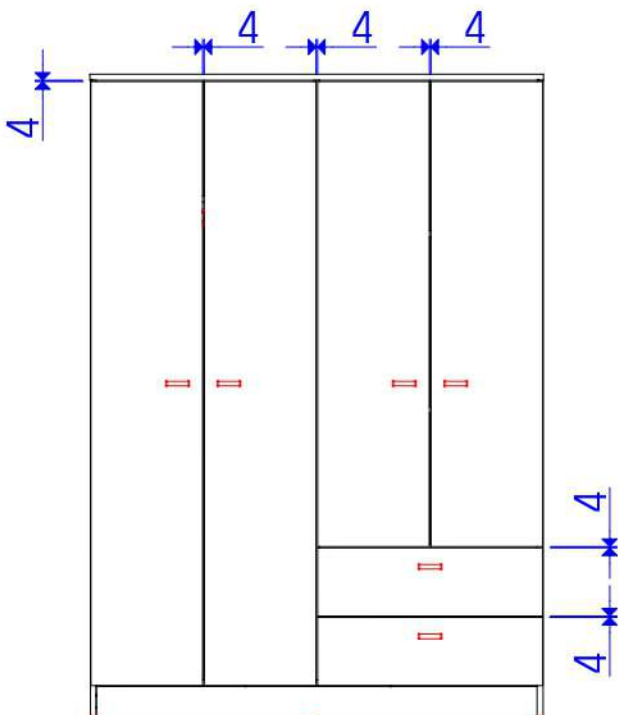
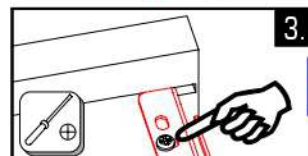
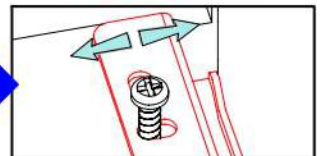
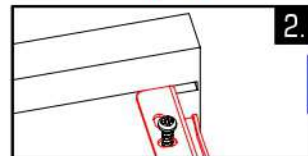
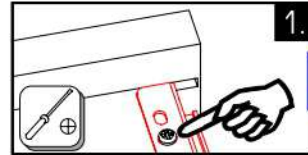
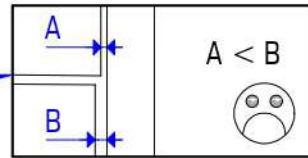
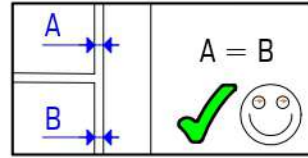
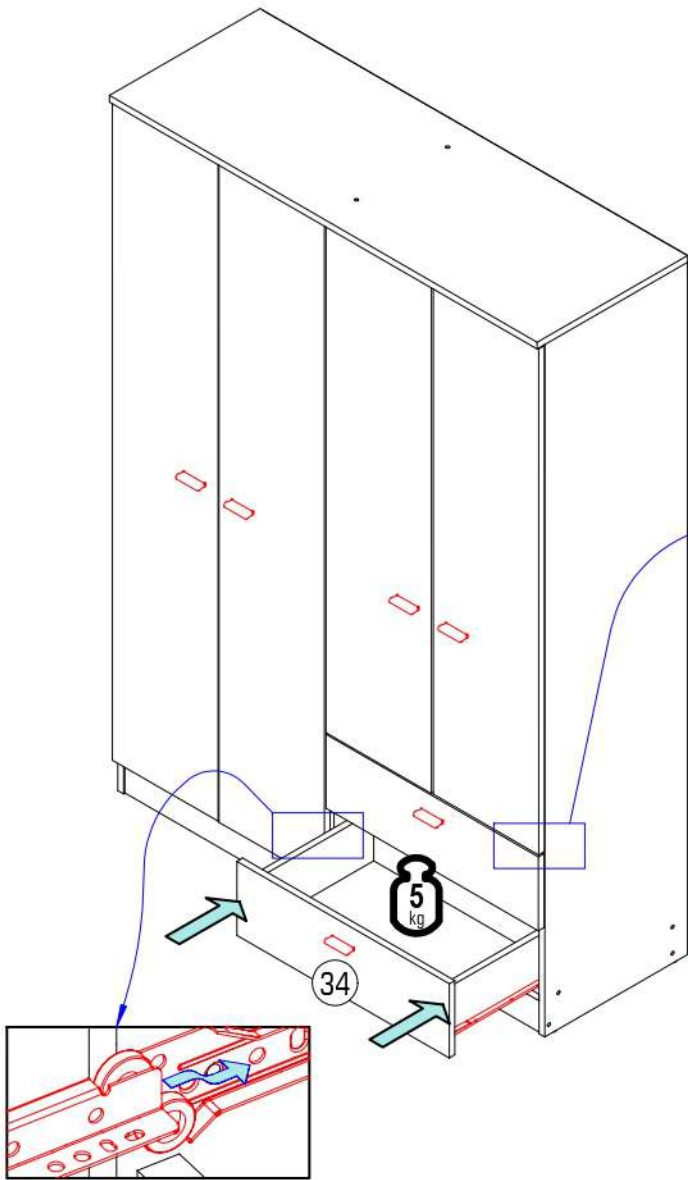

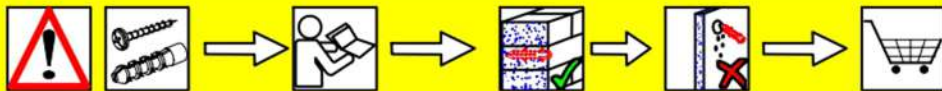

RO Prudență! Zidul trebuie examinat înainte de asamblare prizele de perete sunt adecvate numai pentru utilizarea în zidărie fermă, cum ar fi betonul bloc sau cărămidă. Nu folosiți zidăria zidurilor de perete, cum ar fi cărămida goală, blocul ușor, suprafețe cum ar fi gips-carton sau altă încadrare sisteme. Dacă este cazul, trebuie folosite anumite prize de perete! Acestea sunt disponibile la un magazin specializat (magazin de hardware). În caz de nerespectare, producătorul / vânzătorul cu amănuntul sau importatorul nu își asumă răspunderea.

SI Pozor! Pred montažo preverite stanje stene. Priloženi univerzalni mozniki so izključno samo za uporabo na čvrstem zidovju, kot sta beton in opeka. Stenski mozniki se ne smejo uporabljati pri zidovju kot so votlino opeke, zidaki za lahko gradnjo, mavčne plošče ali druge okvirne gradnje. Pri teh zidovjih morate v danih primerih uporabljati posebne moznike. Ti so na voljo v specializiranih trgovinah (trgovinah z gradbenim materialom) Pri upoštevanju se s strani proizvajalca/trgovca in uvoznika ne prevzame jamstvo.

HR Pažnja! Prije montaže obavezno provjerite svojstvo zida. Priložene univerzalne tiplje namijenjene su isključivo za masivne zidove od betona/opeke. Tiplje za masivne zidove ne smiju se koristiti za zidove kao npr šupljina opeka laki sastavni elementi, gips-kartonske ploče ili drugi modularni načini gradnje. Za te zidove potrebne su eventualno specijalne tiplje! Iste su dostupne u specijaliziranim trgovinama građevinskim materijalom. U slučaju nepridržavanja prethodno navedenih napomena, proizvođač/trgovac i uvoznik ne preuzimaju odgovornost!

HU Vigyázat! Szerelés előtt a falfelületet feltétlenül vizsgálja meg. A mellékelt univerzális tiplj kizárólag stabil falazathoz használható mint például beton/tégla. A fali tiplj nem használható könnyű építőelemekhez, üreg tégla, gipszkarton lapokhoz vagy más fűvázás építőanyagokhoz. Ezekhez a falfelületekhez csak speciális tiplik használhatóak, melyek szaküzletekben (barkácsáruházakban) beszerezhetőek. Fentiek figyelmen kívül hagyása esetén a gyártó/kereskedő vagy forgalmazó nem vállal felelősséget.

CZ Upozornění! Před montáží je nutné zkontrolovat stav stěny. Přiložené univerzální hmoždinky jsou určeny pouze k použití pro pevné zdivo jako beton/cihly. Hmoždinky do zdi se nesmí používat u dutinová cihla, zdiva jako porovité stavební kámen, sádrokartonová deska nebo jiný měkký materiál. U těchto zdiv jsou nutné použít speciální hmoždinky! Jsou k dostání v speciálních prodejních se stavebním materiálem. Při nedodržení těchto pokynů výrobce/prodejce a dovozce neručí za způsobené škody.

SK Upozornenie! Pevnosť steny sa musí pred montážou bezpodmienečne skontrolovať. Priložené univerzálne hmoždenky používajte jedine pre pevné murivo ako je betón/tiehla. Hmoždenky sa nesmú používať v prípade ľahkého stavebného muriva, dutá tiehla, Sádrokartónová doska, alebo iných konštrukcií rámu. U týchto stien je nutné použiť špeciálne hmoždenky! Tieto je možné dostať v špeciálnych predajniach so stavebným materiálom. Pri nedodržíaní pokynov nepreberajú výrobca/výrobca/predajca a dodávateľa zodpovednosť za vzniknuté škody.

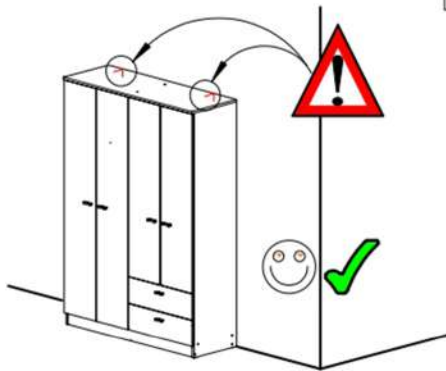

SK	VÝSTRAHA	RO	AVERTIZARE
CZ	VAROVÁNÍ	HU	FIGYELEM
HR	UPOZORENIE	SI	OPOZORILO

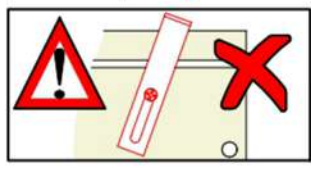
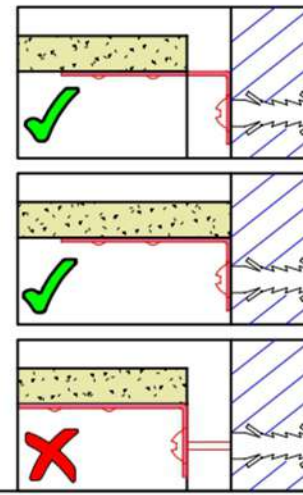
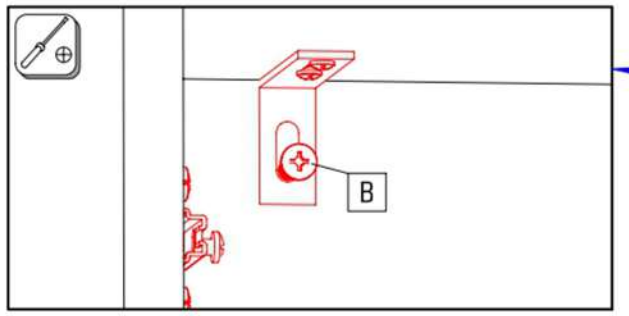
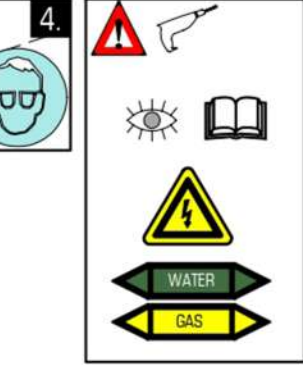
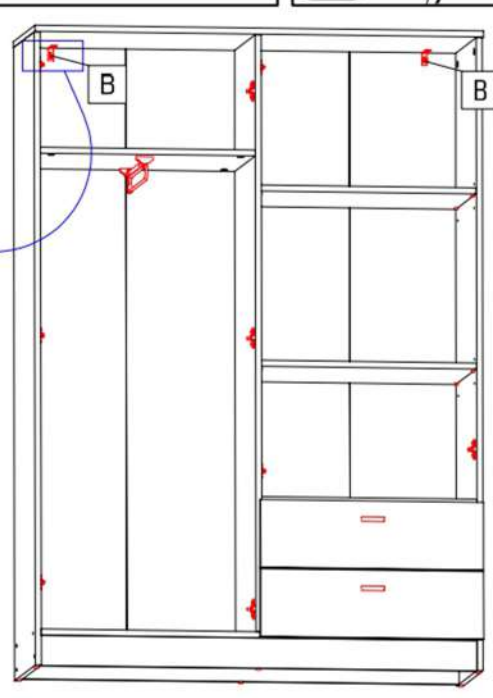
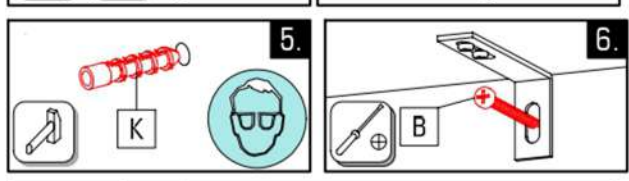
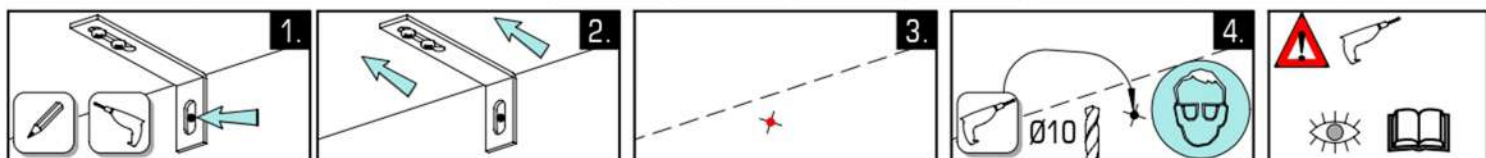
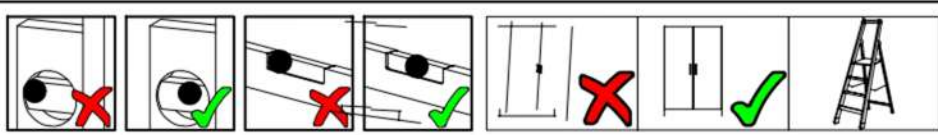
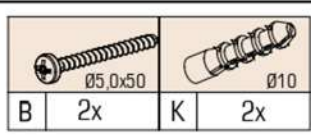
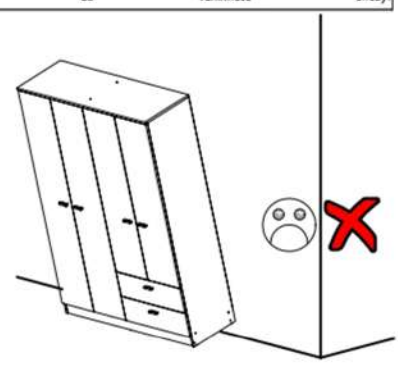

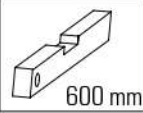
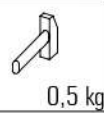
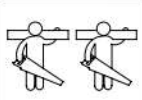

30 min

PZ 1, PZ 2

0,5 kg

3m





600 mm

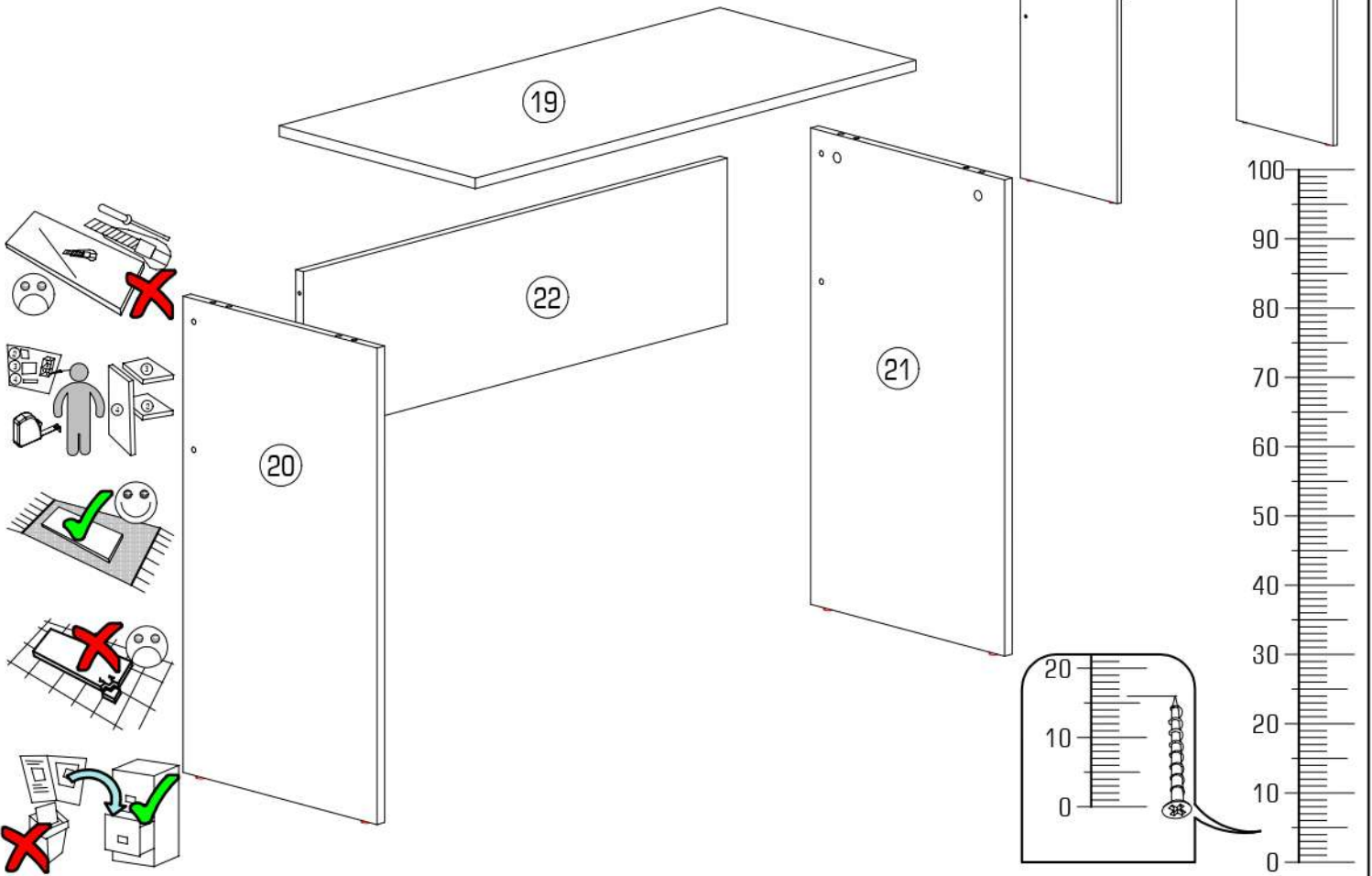

23540	19	900*400*16	1x	4/5
23541	20	714*396*16	1x	4/5
23542	21	714*396*16	1x	4/5
23543	22	866*248*16	1x	5/5

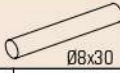

22300,00		22300,00			
A	4x	A1	1x	F	4x
30091,00		27000,00		70013,01	
J	4x	L	4x	U	4x
				70021,01	
				V	4x

			
L	J	U	V
4x	4x	4x	4x

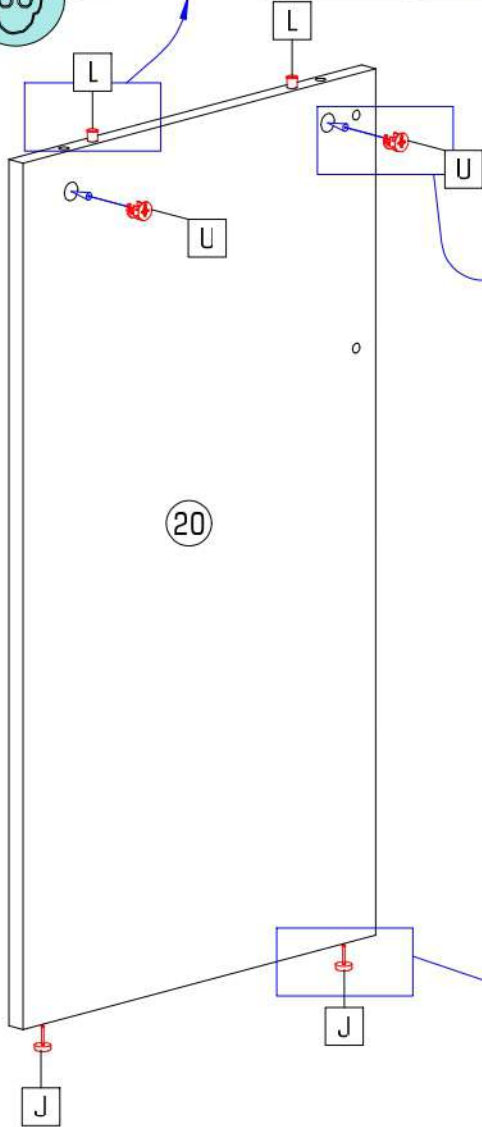
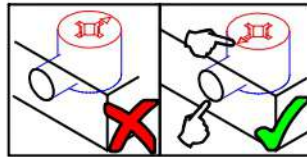
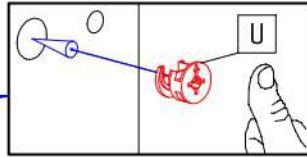
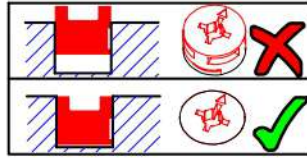
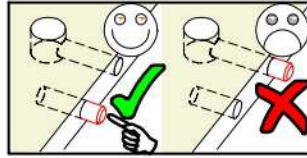
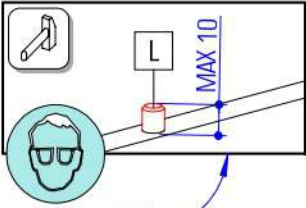

20

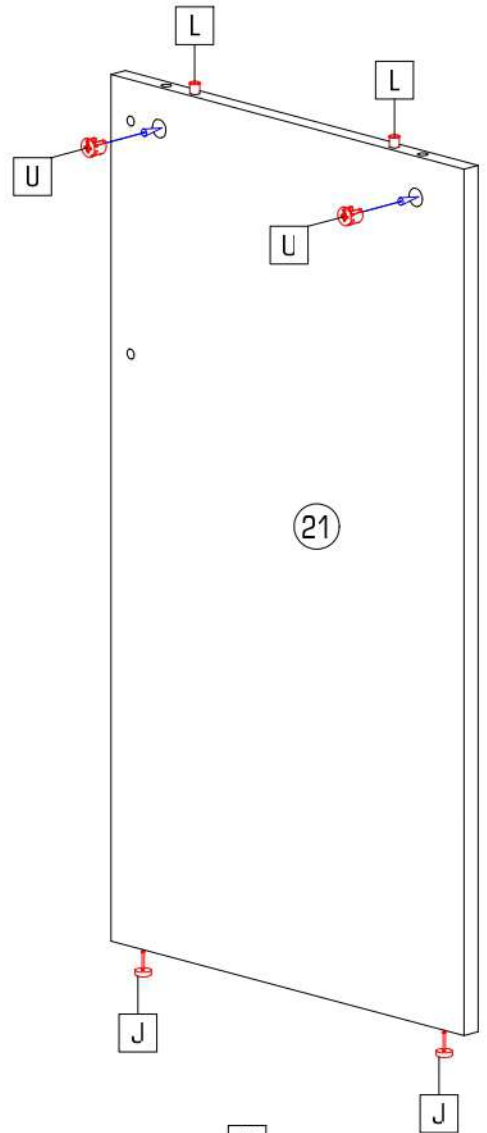

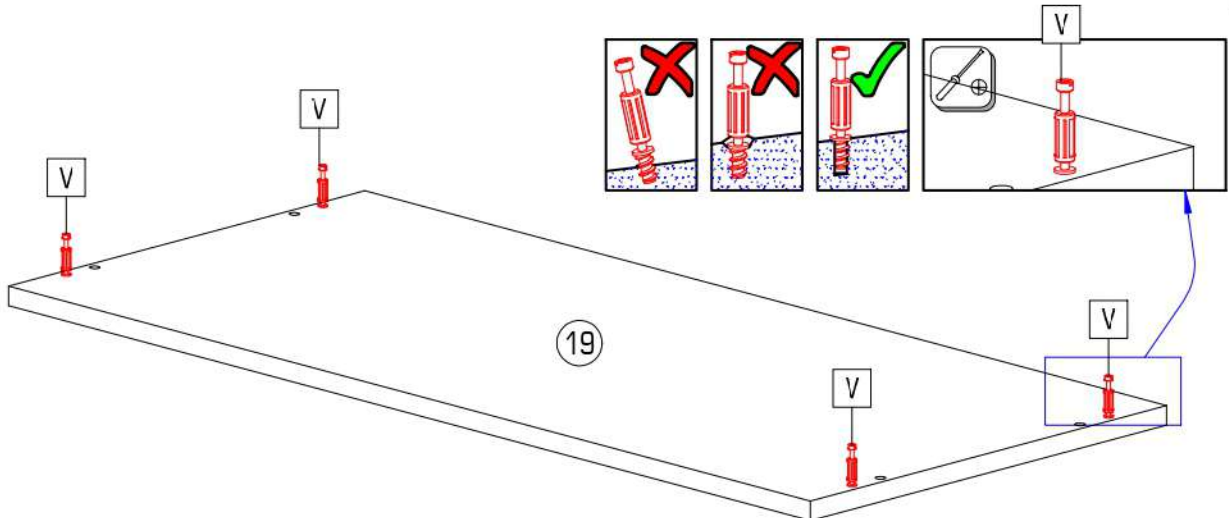
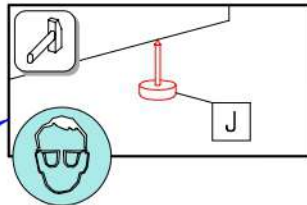
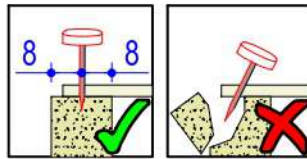

21

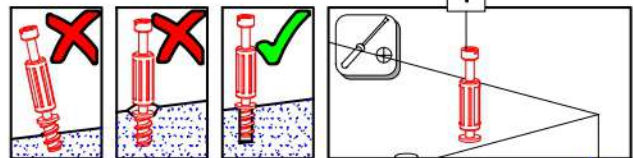

19



		
Ø7.0x50		
A 4x	F 4x	G 4x

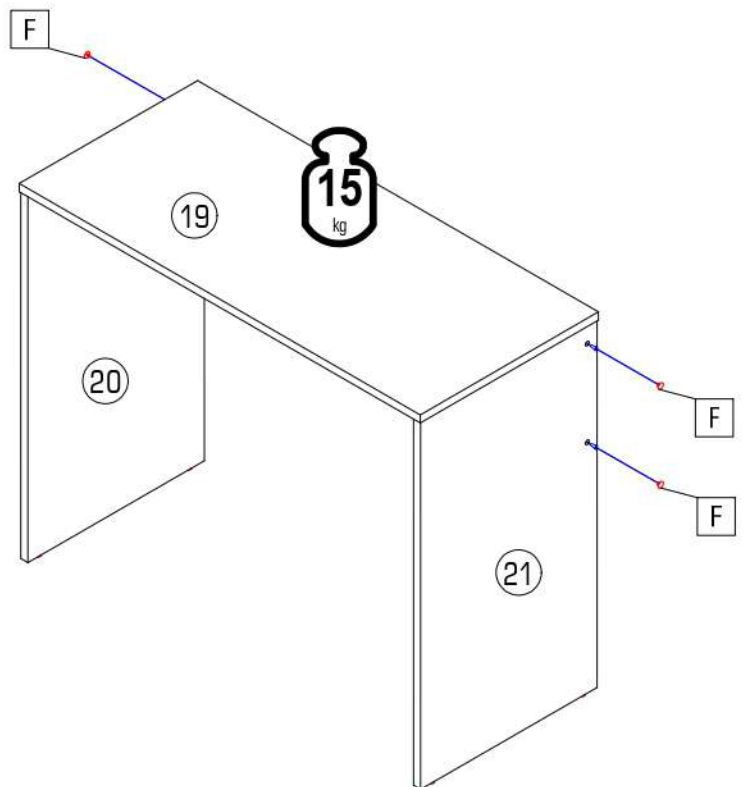
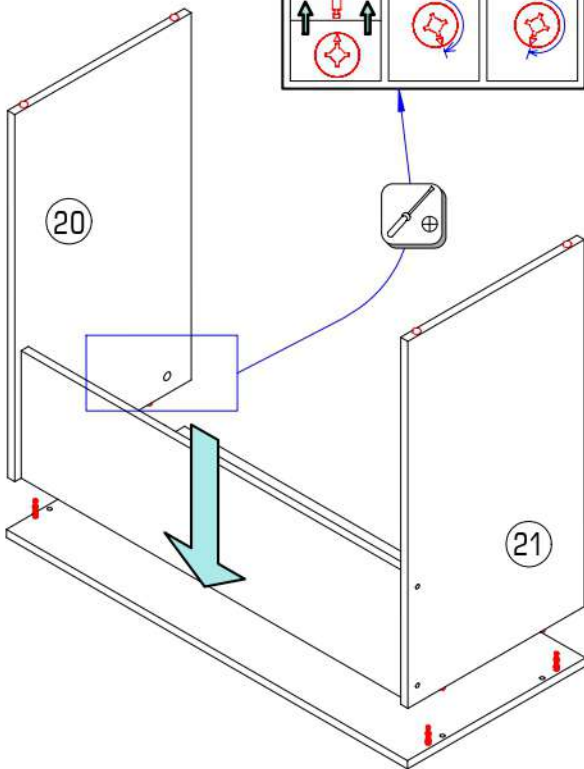
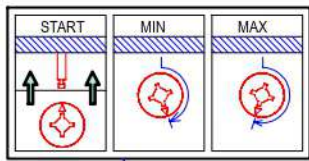
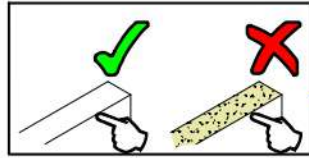
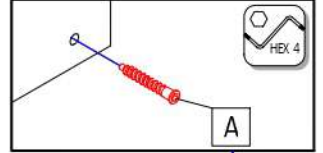
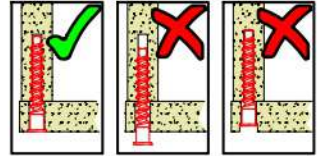
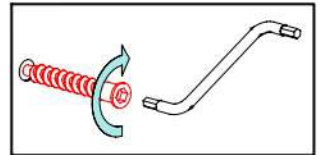
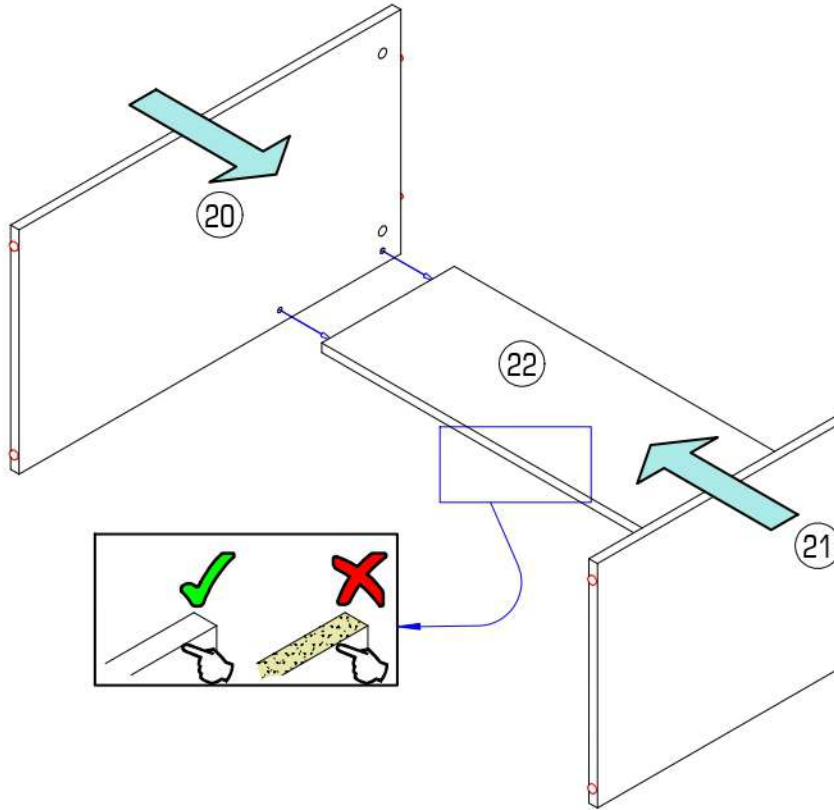
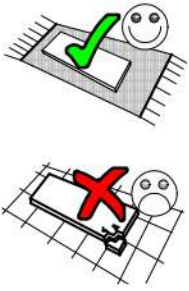

18 /34

	900		148
	150		[mm]

ORBI

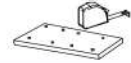
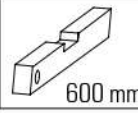
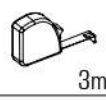
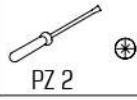
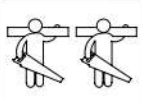

23538	(17)	900*150*16	1x	4/5
23539	(18)	894*132*16	1x	4/5

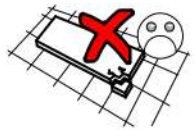
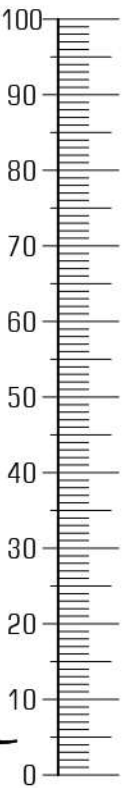
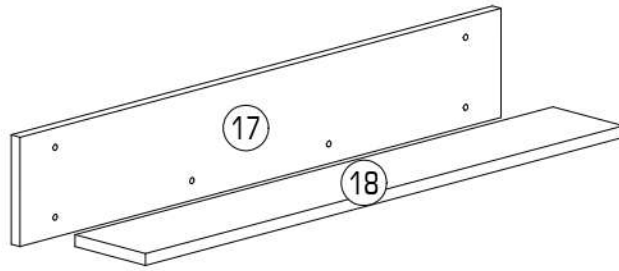
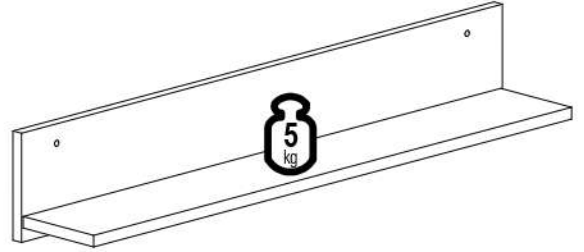

	22300,00		22302,00		24102,02	
Ø7,0x50		Ø7,0x70		Ø12		
A 4x		G 2x		T 2x		W 2x

	Ø7,0x50
A	4x

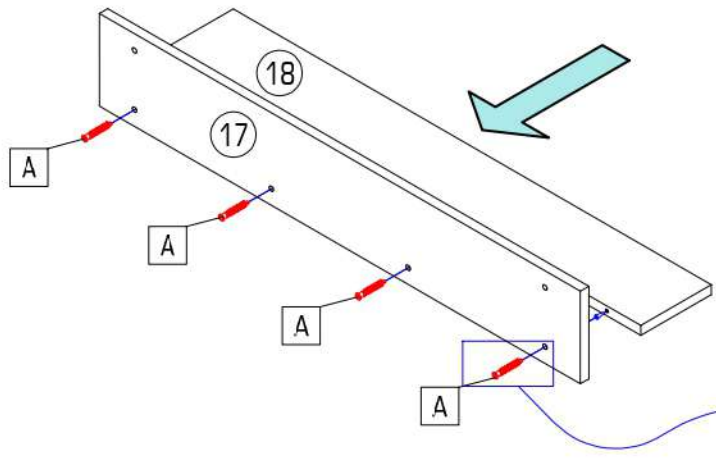

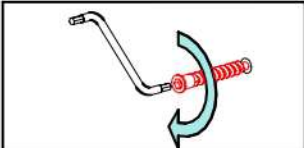

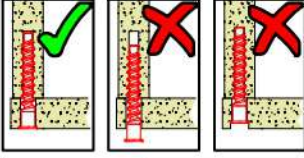

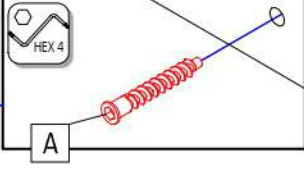

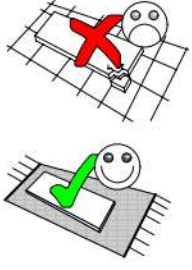



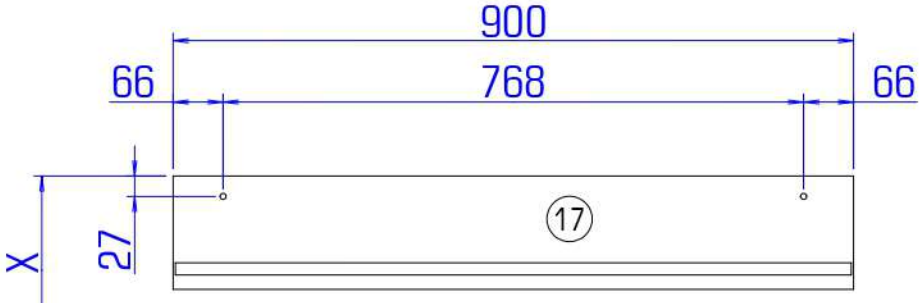

1.





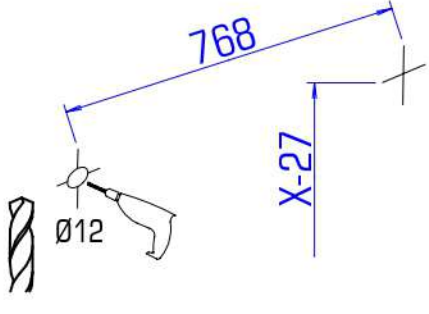

2.







3.

	Ø12
W	2x





	G	2x		T	2x
		Ø7,0x70			

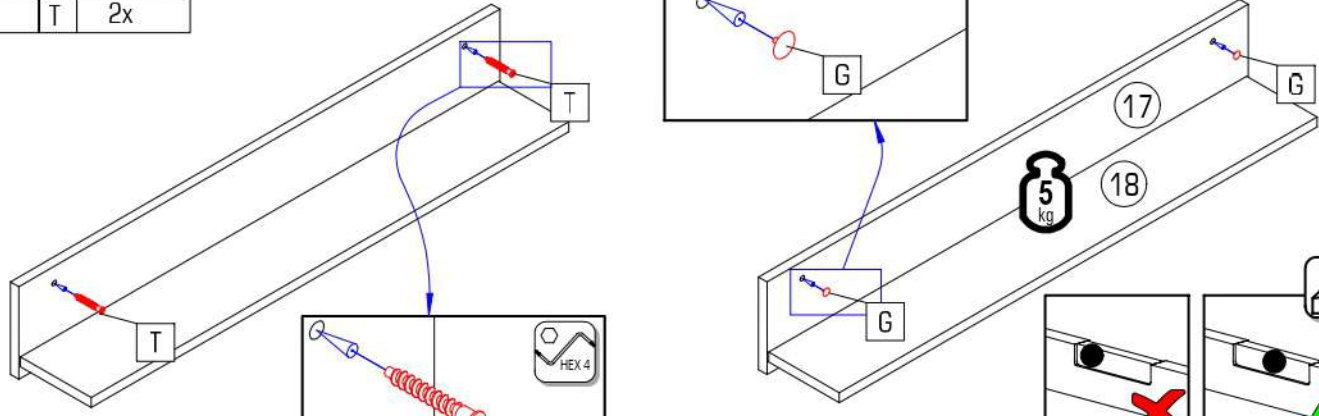

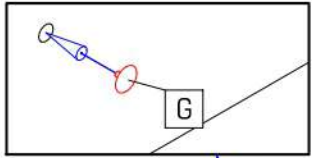

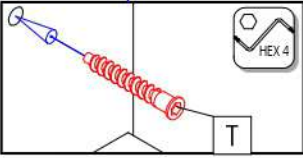

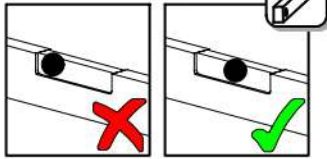

20 /34

300 253
1700 [mm]

ORBI

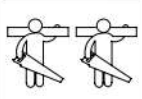

PZ 2



0,5 kg



3m

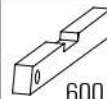

600 mm



Ø10





HEX 4

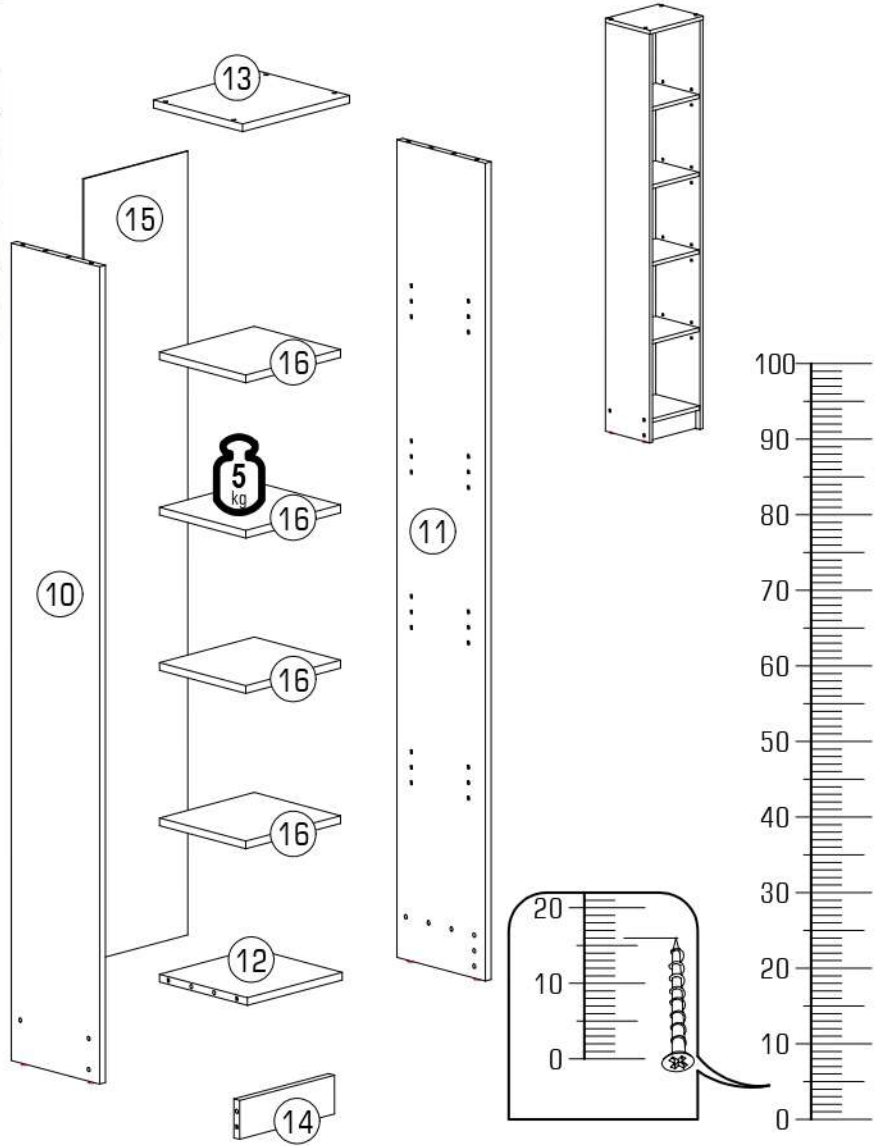
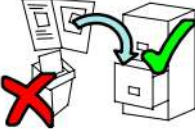

23532	10	1684*248*16	1x	5/5
23531	11	1684*248*16	1x	5/5
23533	12	266*246*16	1x	5/5
23534	13	300*250*16	1x	5/5
23535	14	266*80*16	1x	1/5
23536	15	1614*292*3	1x	2/5
23537	16	266*242*16	4x	5/5





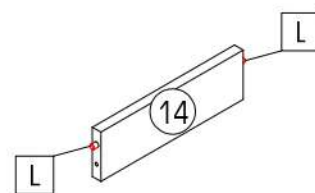
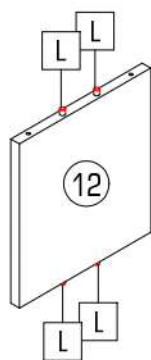
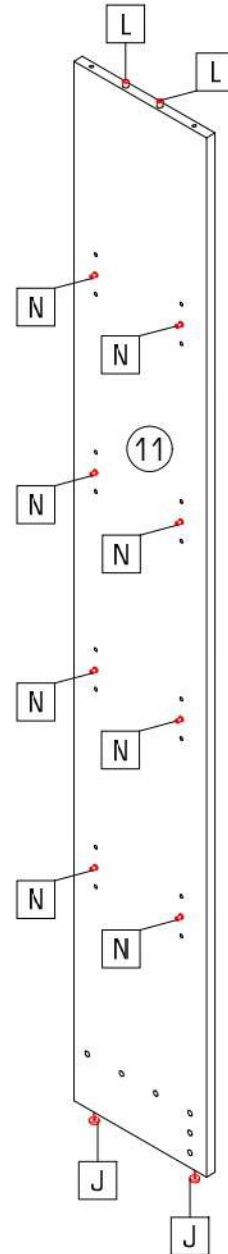
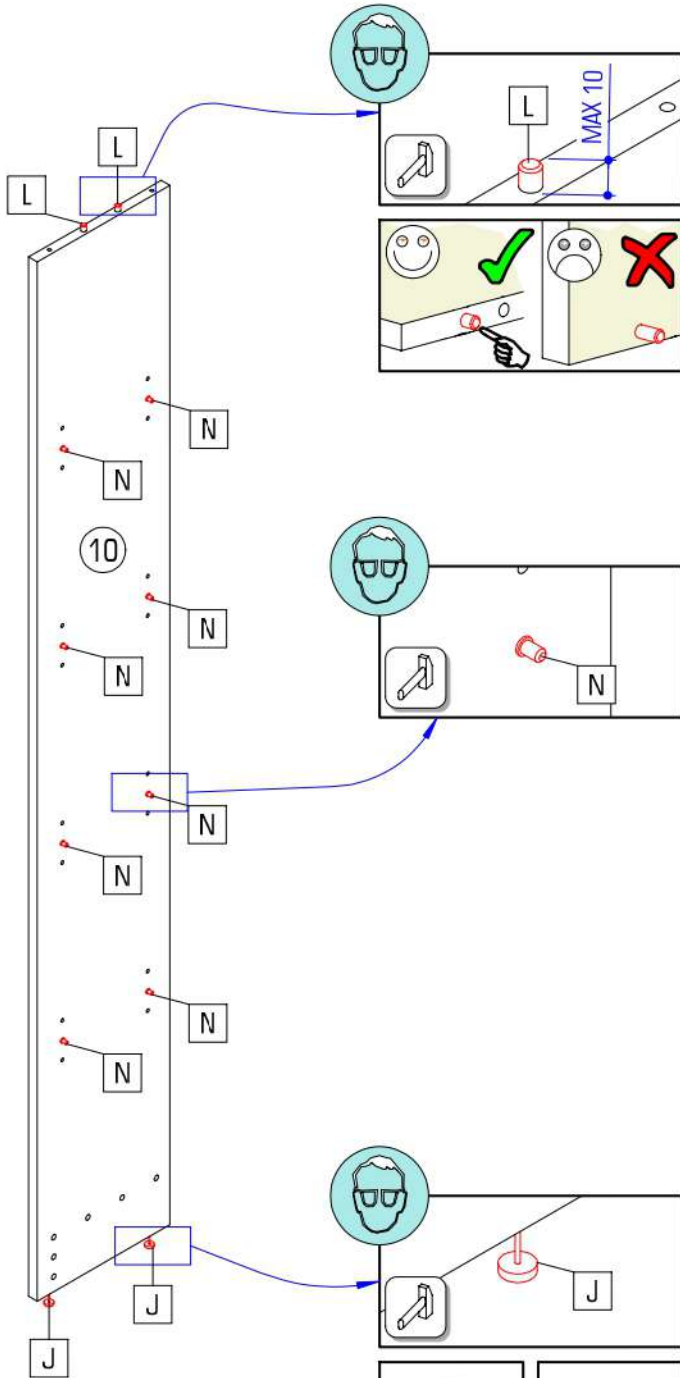

22300,00		22255,00		22244,01			21102,00		
A	10x	B	2x	E	4x	G	10x	H	50x
30091,00		24101,00		27000,00		35101,01		31103,00	
J	4x	K	2x	L	10x	N	16x	P	2x

		
J	L	N
4x	10x	16x

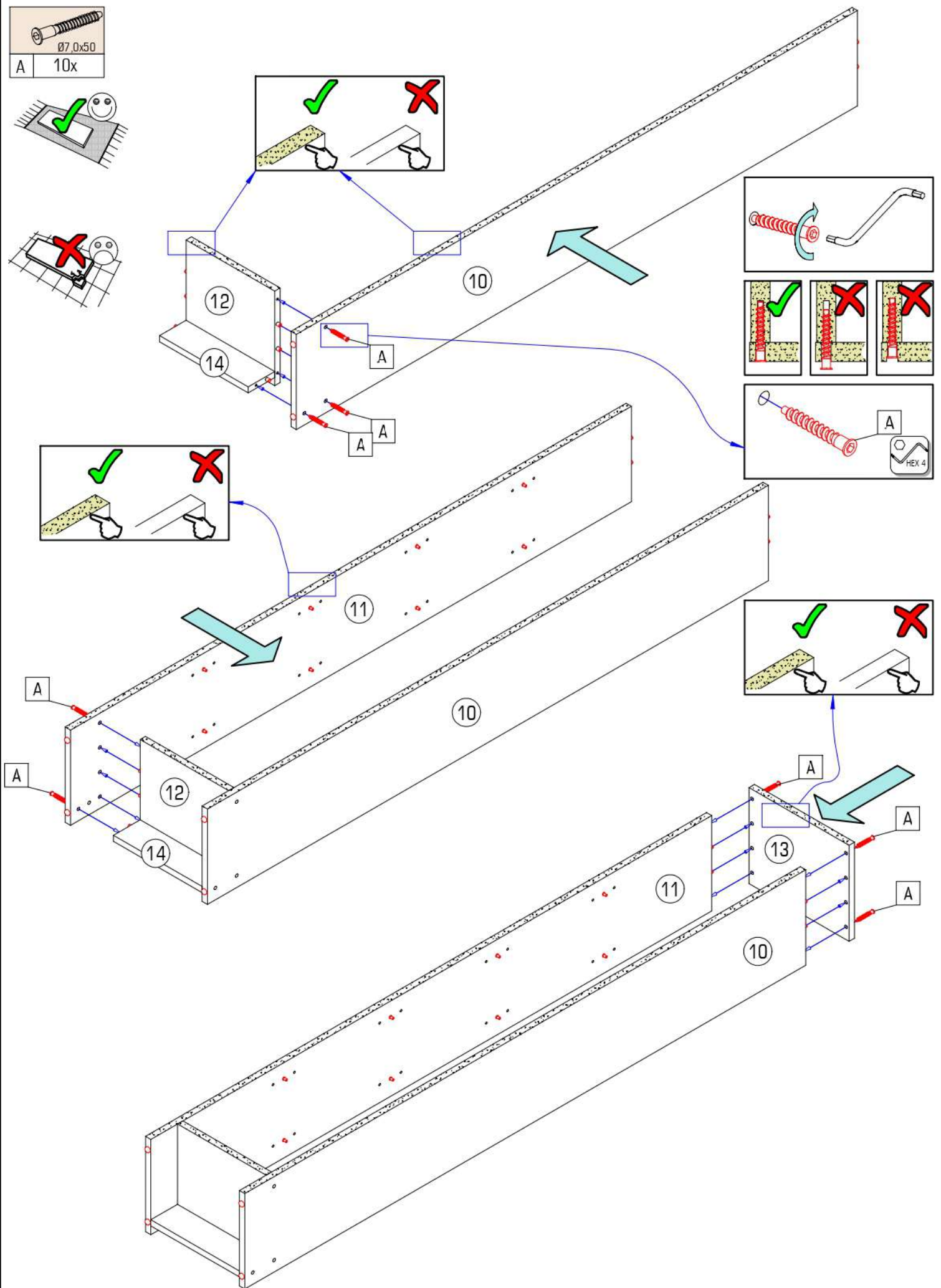
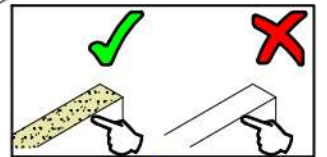
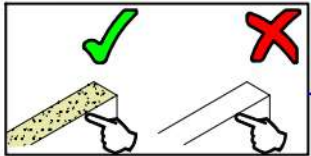
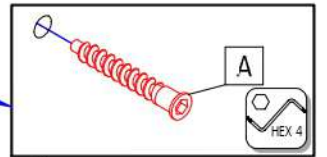
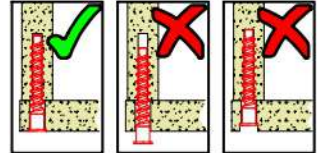
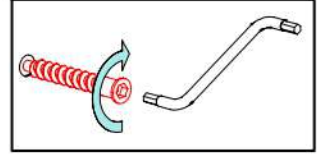
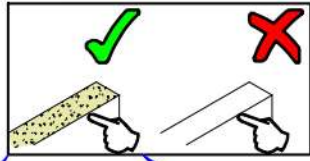
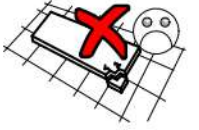





Ø7.0x50
A 10x

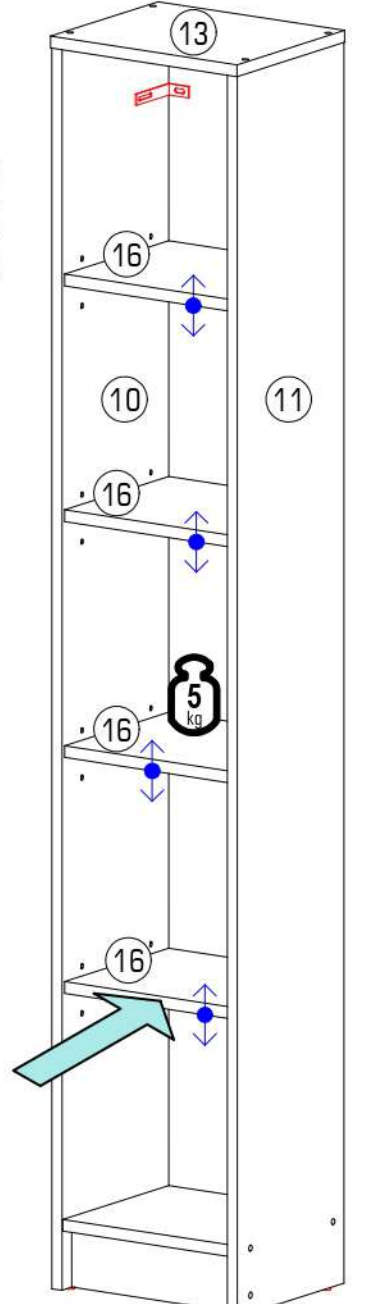
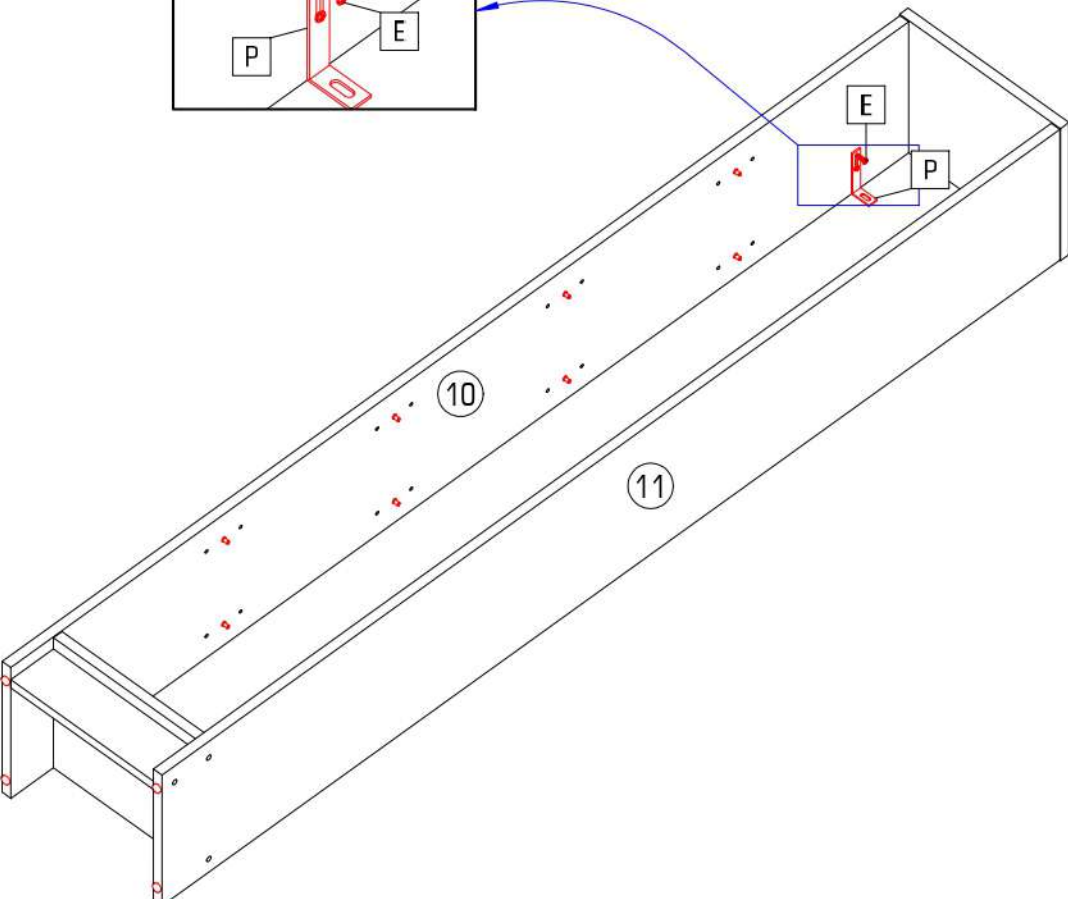
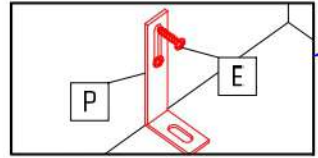
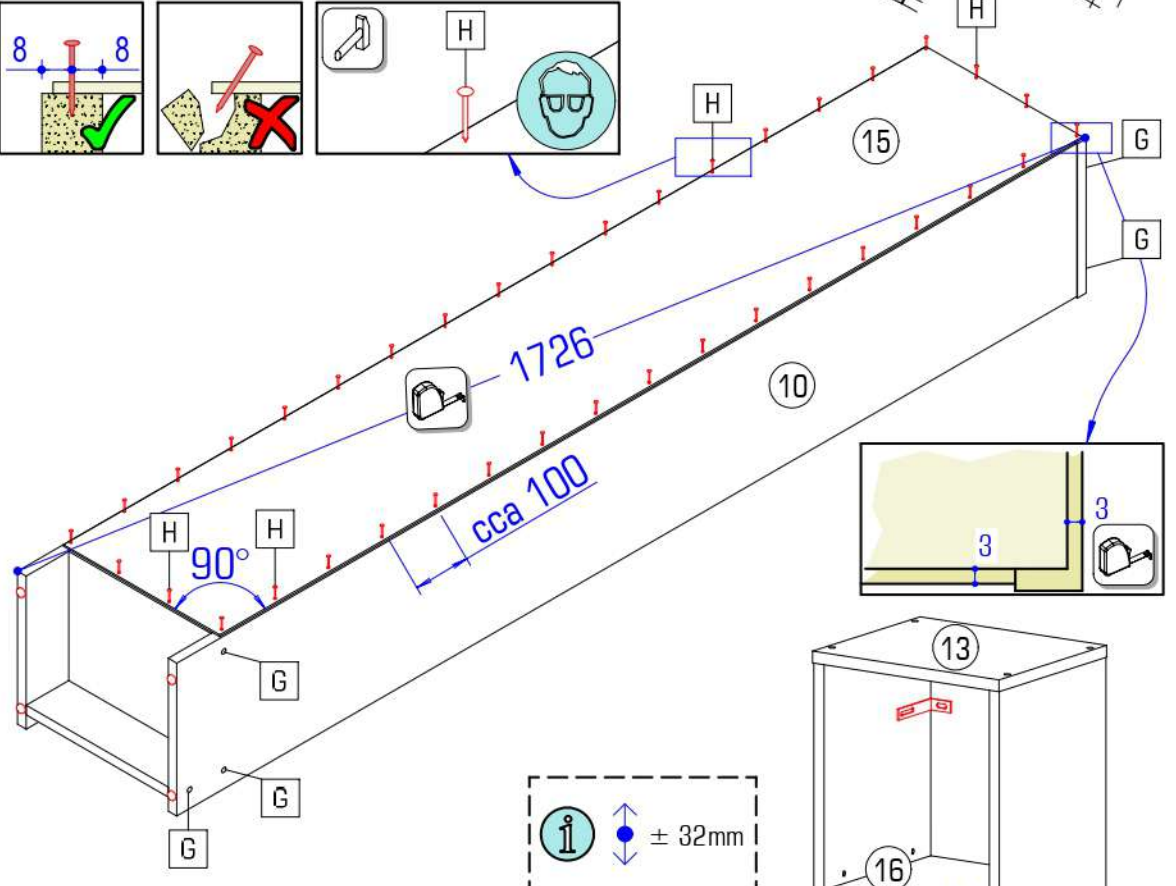
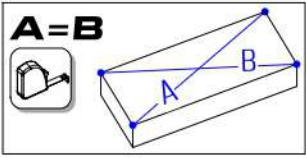
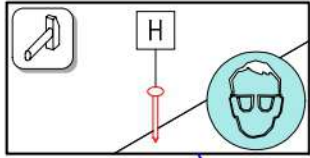
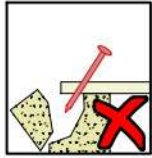
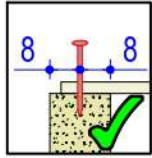
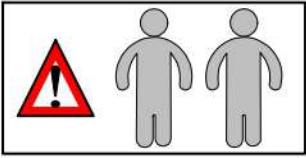
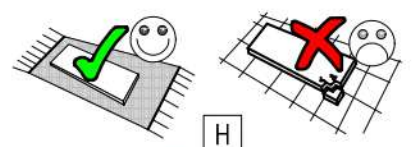

			
E 4x	G 10x	H 38x	P 2x



	Ø5,0x50		Ø10
B	2x	K	2x

 



 

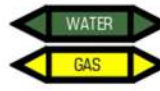



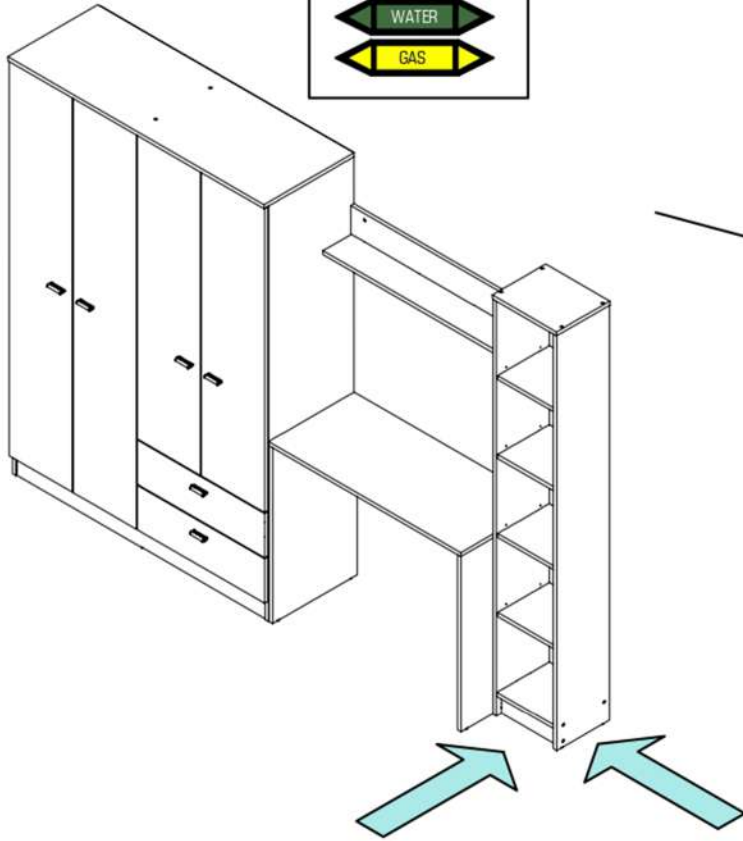
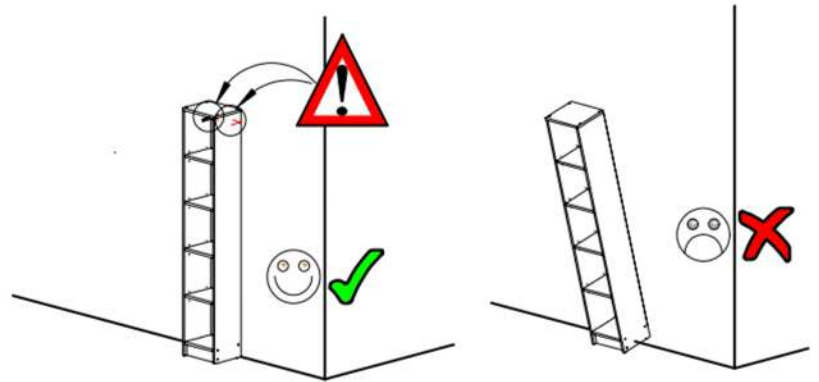



SK	VÝSTRAHA	RO	AVERTIZARE
CZ	VAROVÁNÍ	HU	FIGYELEM
HR	UPOZORENIE	SI	OPOZORILO







1.  

2.  

3. 

4.  Ø10 

5.  K 

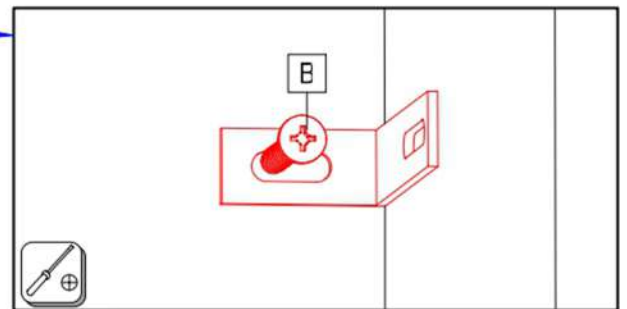
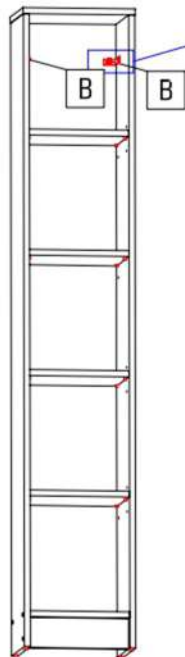

6.  B 













 

















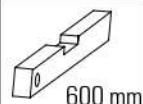
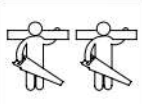

ID	ID	Part	Qty	Code
23523	2	452*400*16	2x	4/5
23524	3	452*400*16	2x	1/5
23525	4	1166*399*16	2x	3/5
23528	5	435*399*16	2x	1/5
23526	6	1200*422*16	2x	3/5
23527	7	1190*462*3	2x	3/5
23529	8	444*296*16	4x	2/5
23530	9	444*296*16	4x	2/5

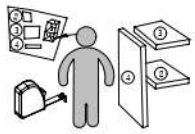
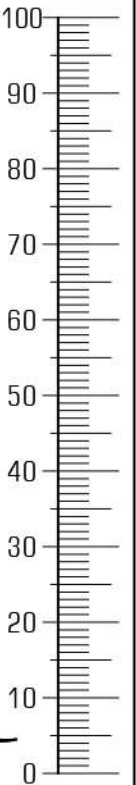
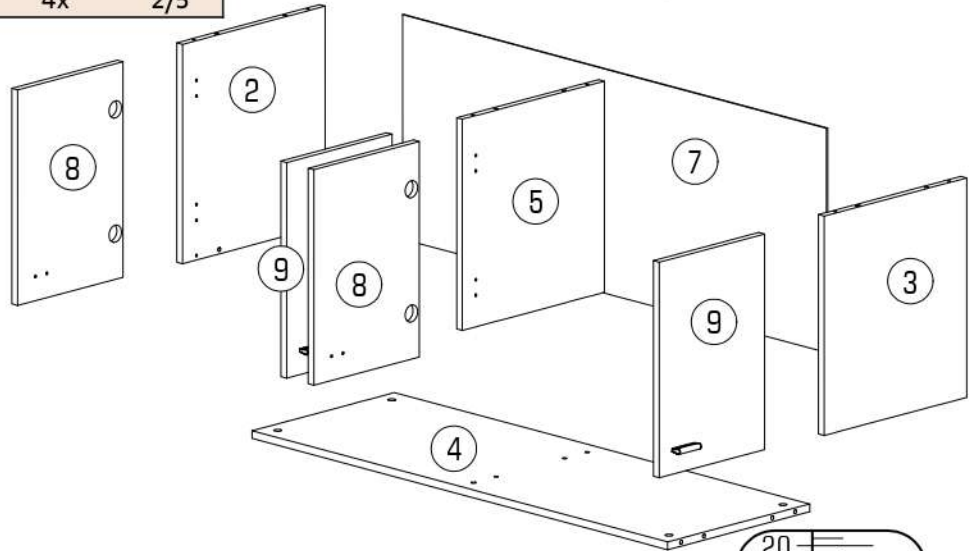
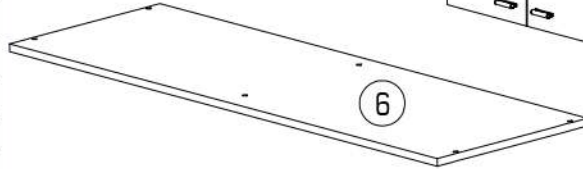
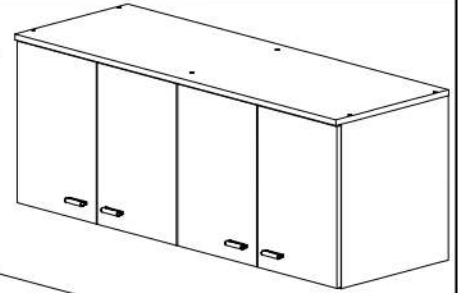

2x

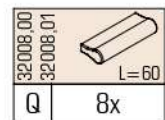
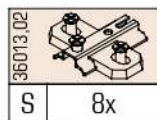
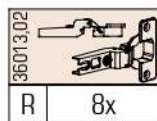
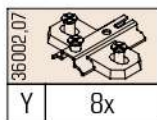
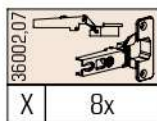
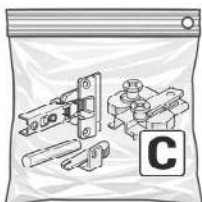

223000,00		Ø7,0x50	222555,00		Ø5,0x50	222880,00		Ø4x30	222443,00		Ø3,5x15	222444,01		Ø3,5x16	F	8x	G	16x
A	16x	B	4x	C	16x	D	32x	E	8x	F	8x	G	16x					

21102,00		Ø1,6x20	24101,00		Ø10	27000,00		Ø8x30	22601,00		31103,00		70013,01		Ø15x13	70021,01	
H	75x	K	4x	L	24x	M	10x	P	4x	U	8x	V	8x				

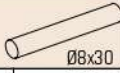

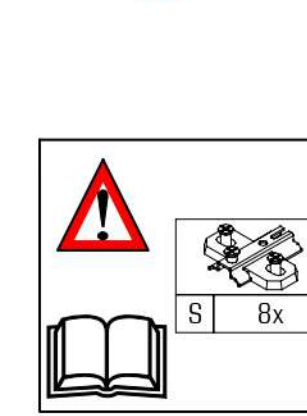
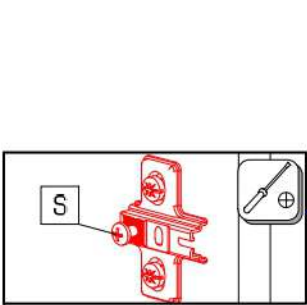
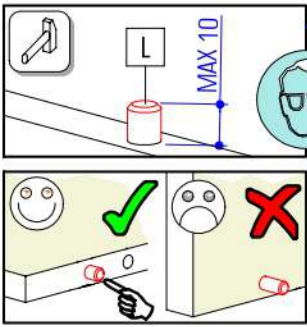

		
L 16x	U 8x	S 8x

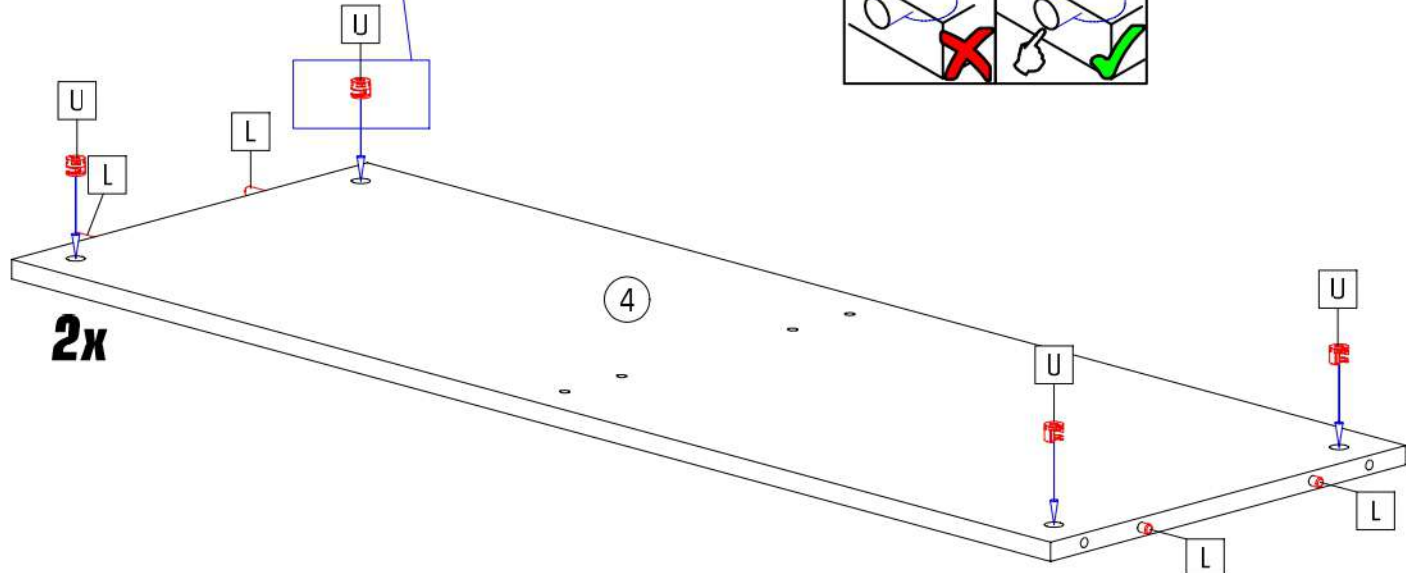
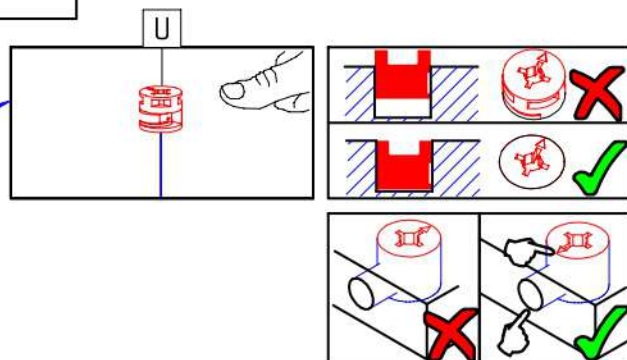
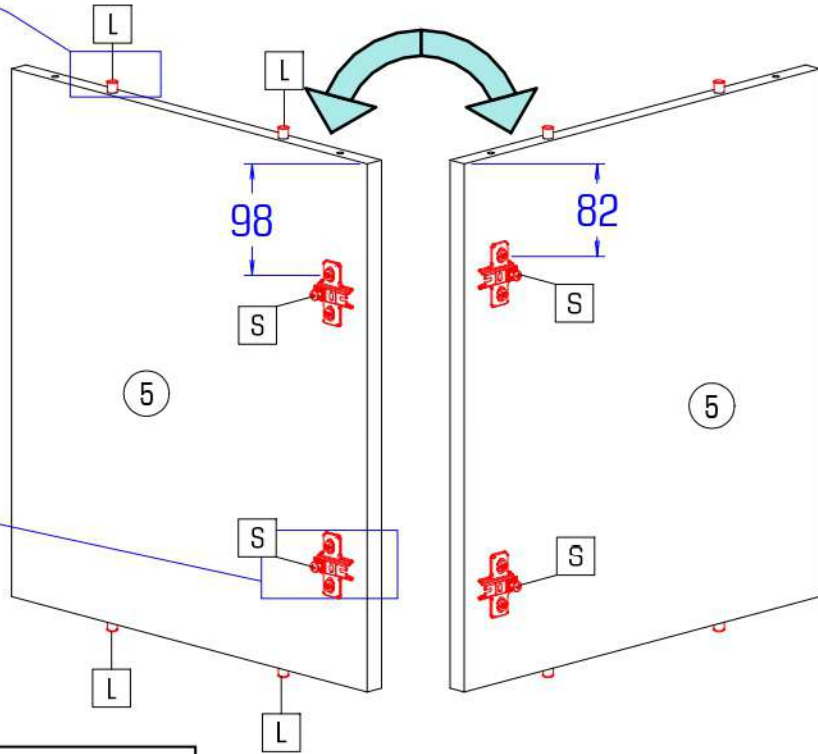

2x



		
L 8x	V 8x	Y 8x

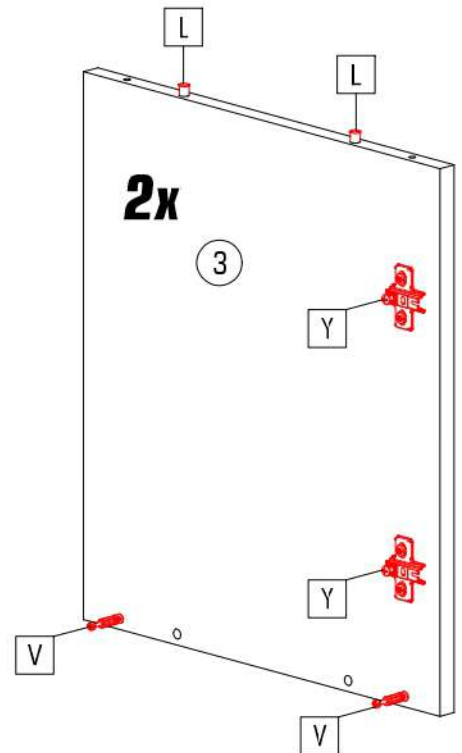
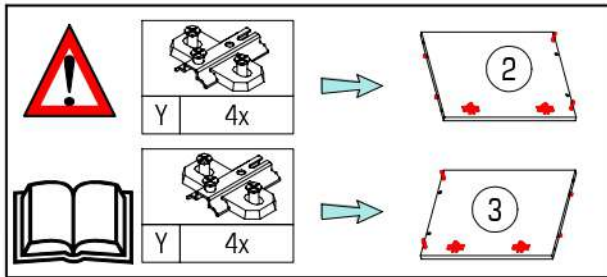
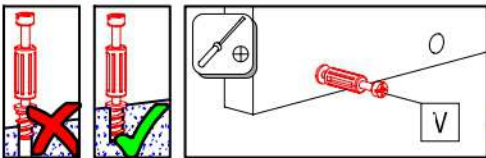
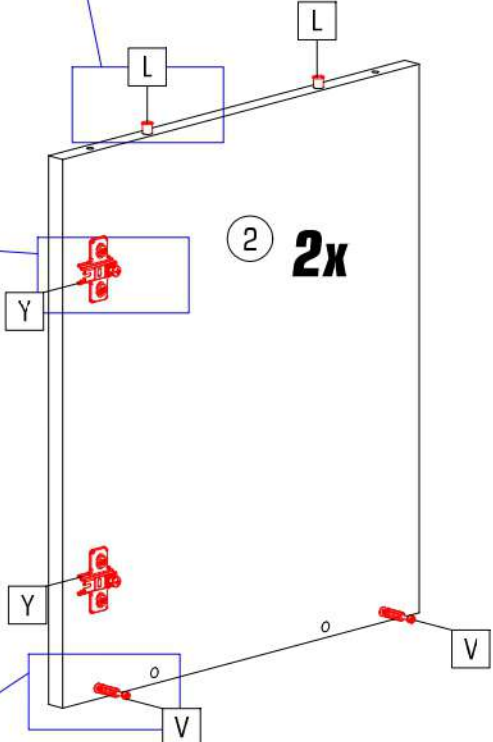
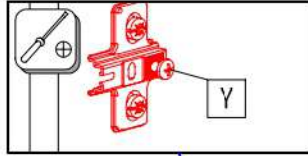
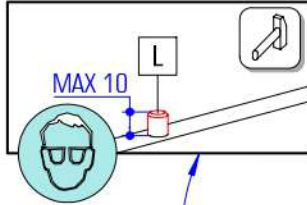

 Ø7,0x50
A 4x

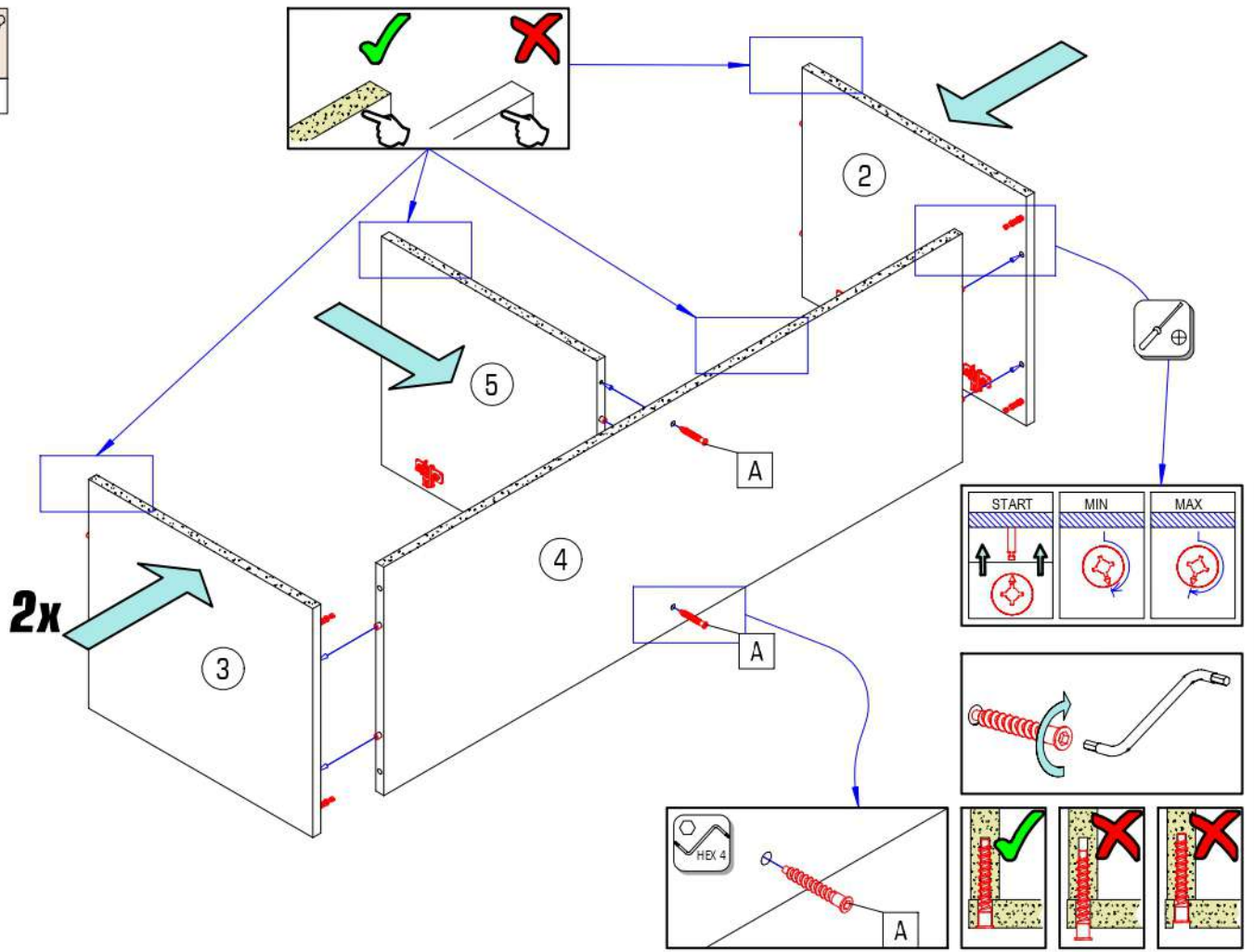

 Ø7,0x50
A 12x

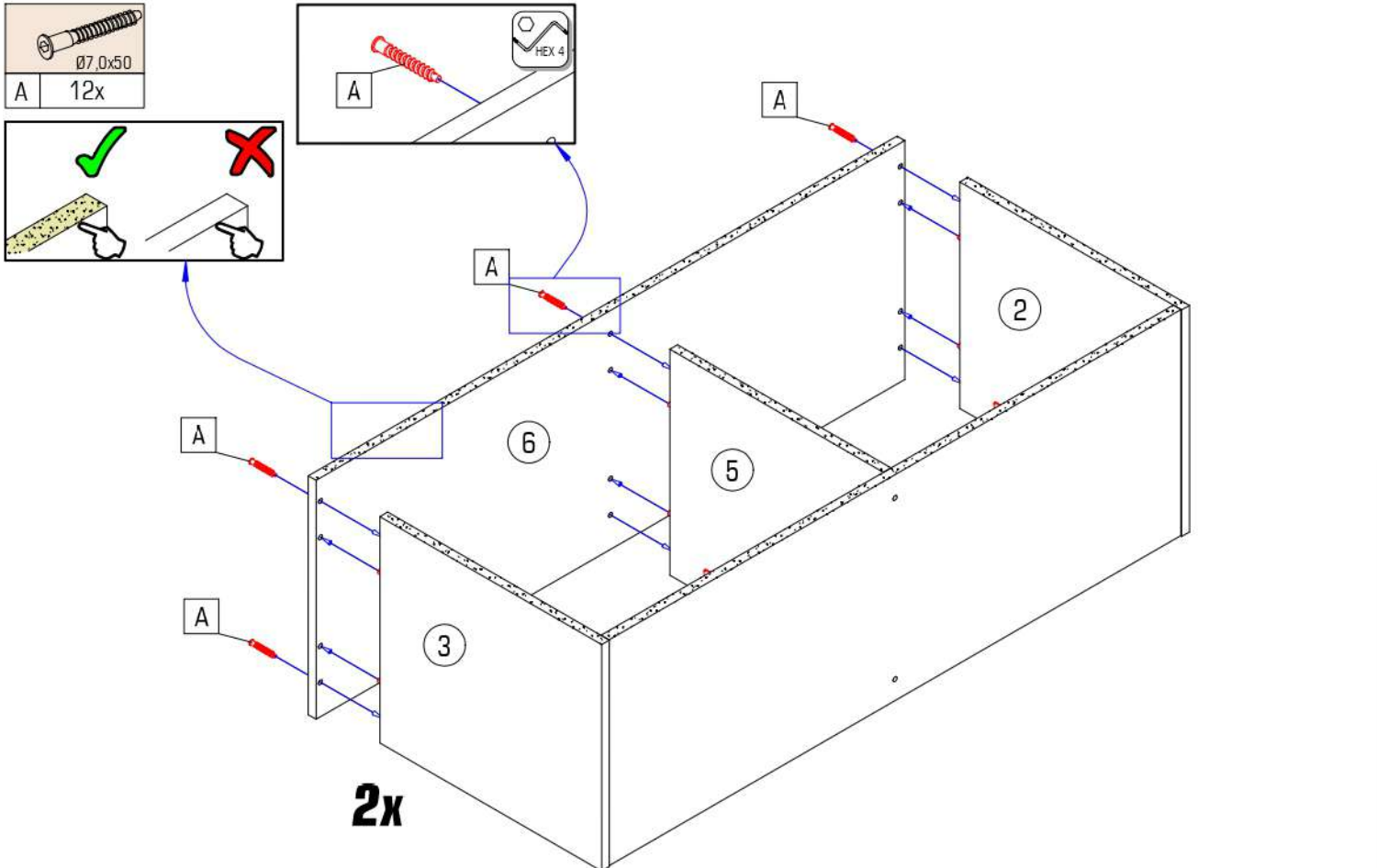

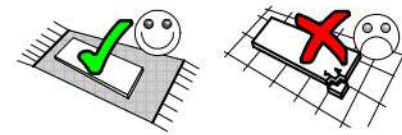
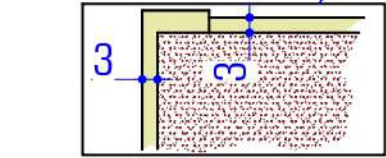
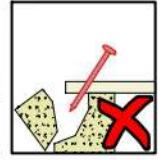
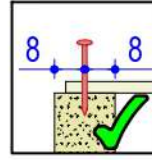
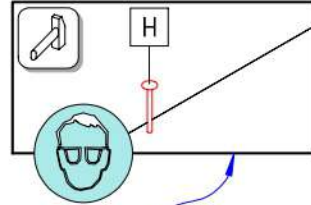
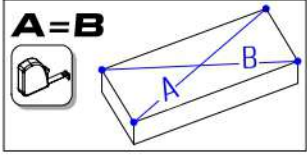
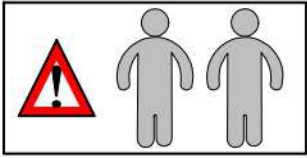
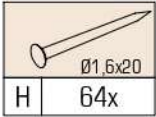



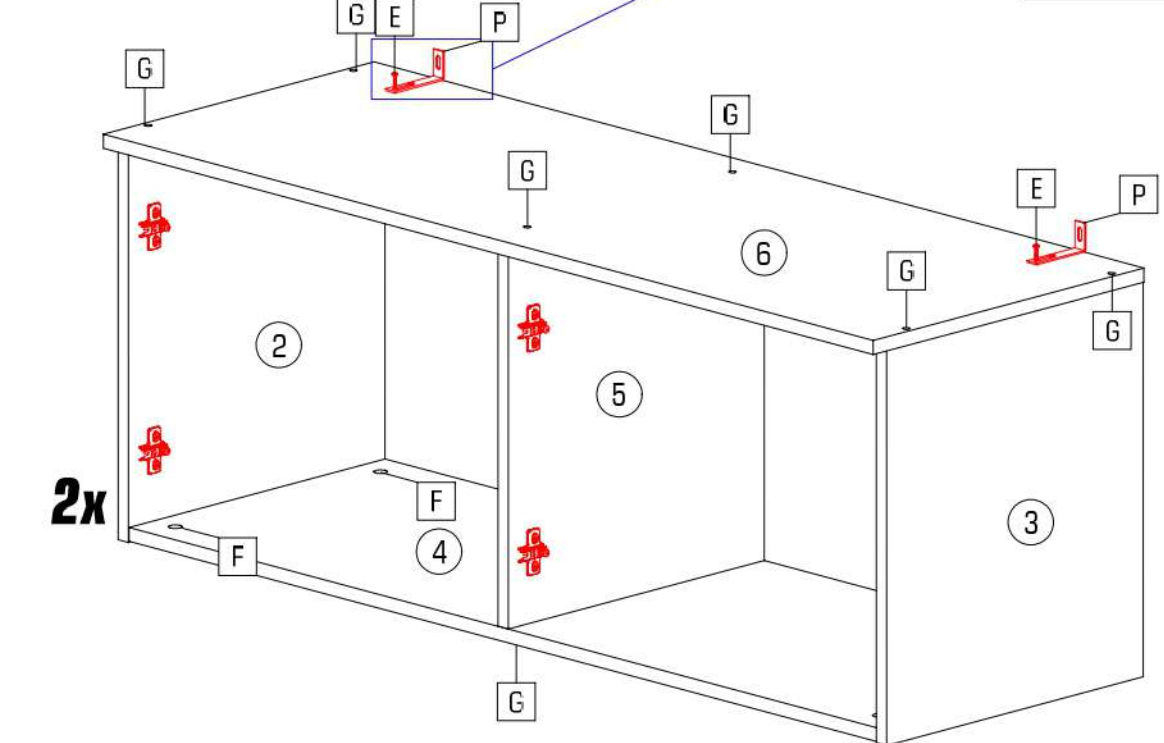
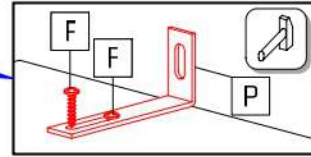
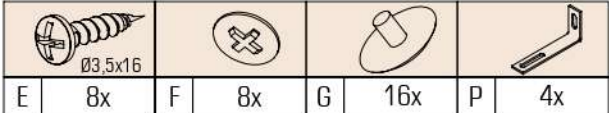
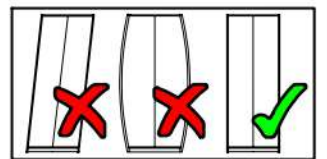
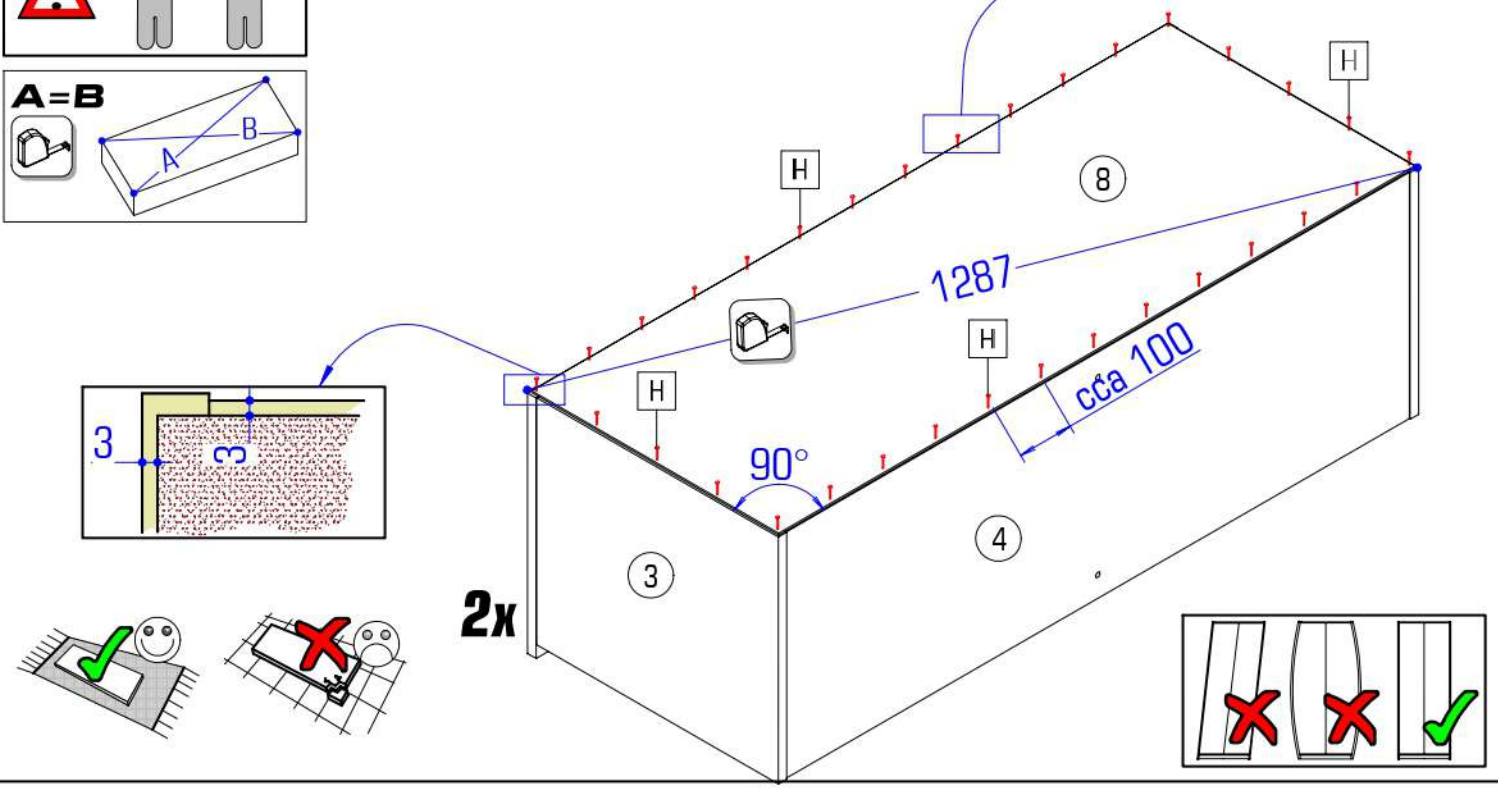

2x



2x

			
C 8x	D 16x	Q 4x	X 8x

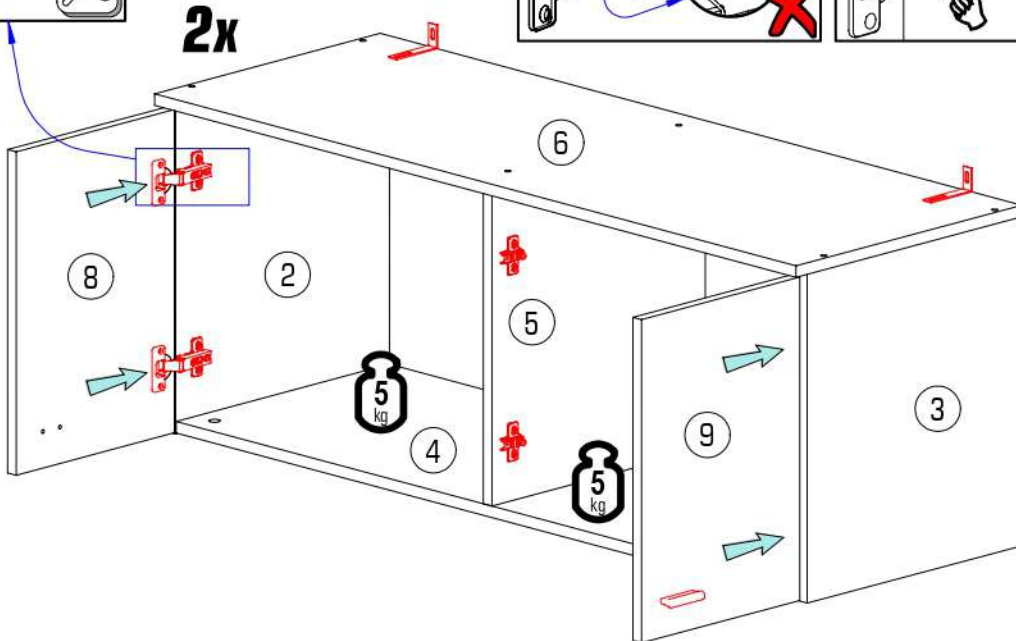
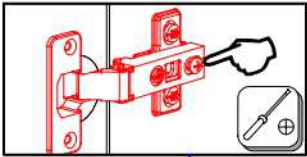
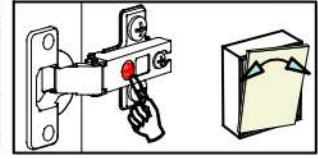
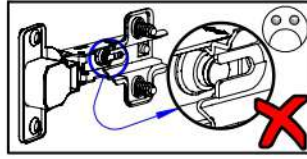
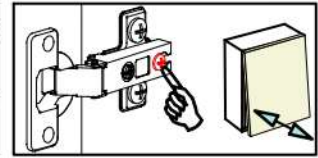
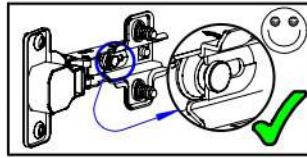
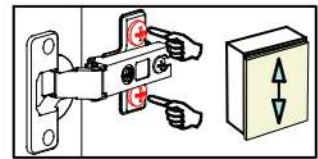
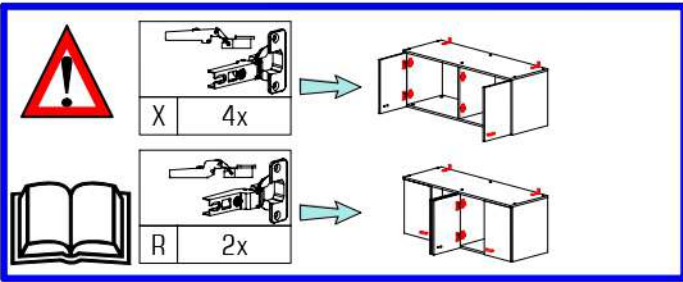
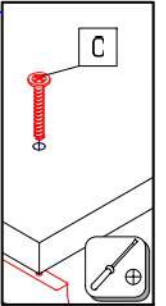
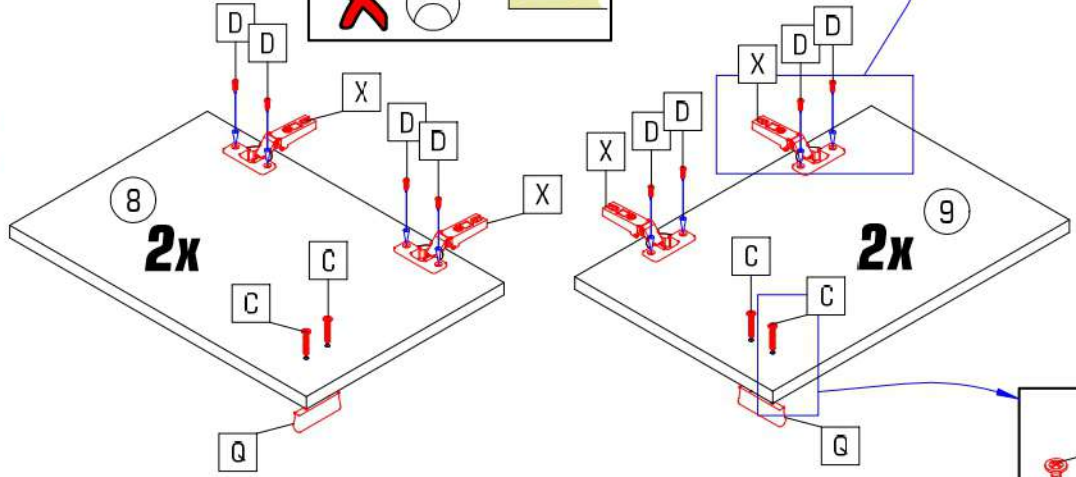
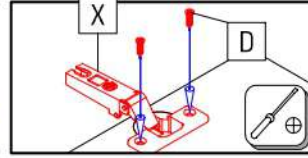
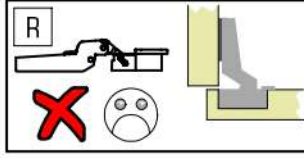
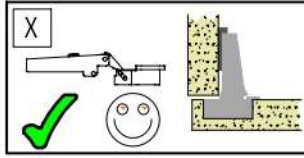
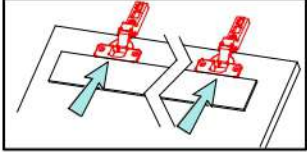
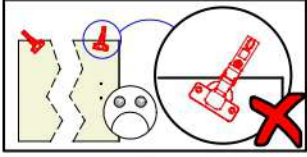
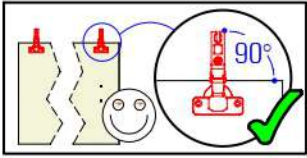

C 8x	D 16x	Q 4x	R 8x

