

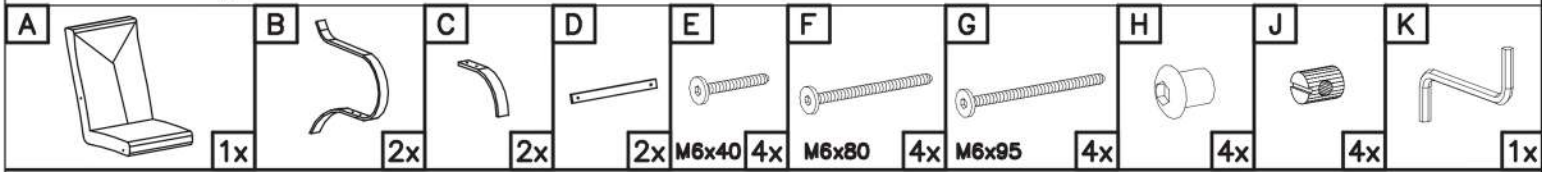

ELORA

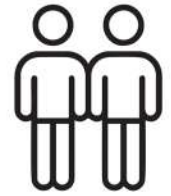

1.

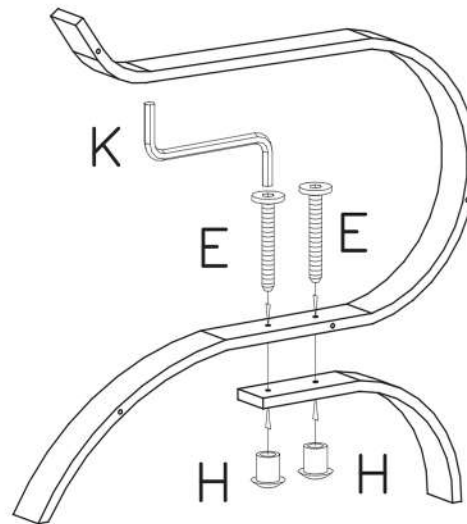

2.

SK: Ponechajte dostatočný priestor na upevnenie sedadla.

CZ: Ponechte dostatečný prostor pro usazení sedáku.

HU: Hagyjon egy kis helyet az ülés beillesztéséhez.

RO: Lăsați puțin spațiu pentru a încăpea partea de șezut.

HR: Ostavite nešto mjesta kako biste postavili sjedalo.

SI: Pustite nekaj prostora, da se sedež prilega.

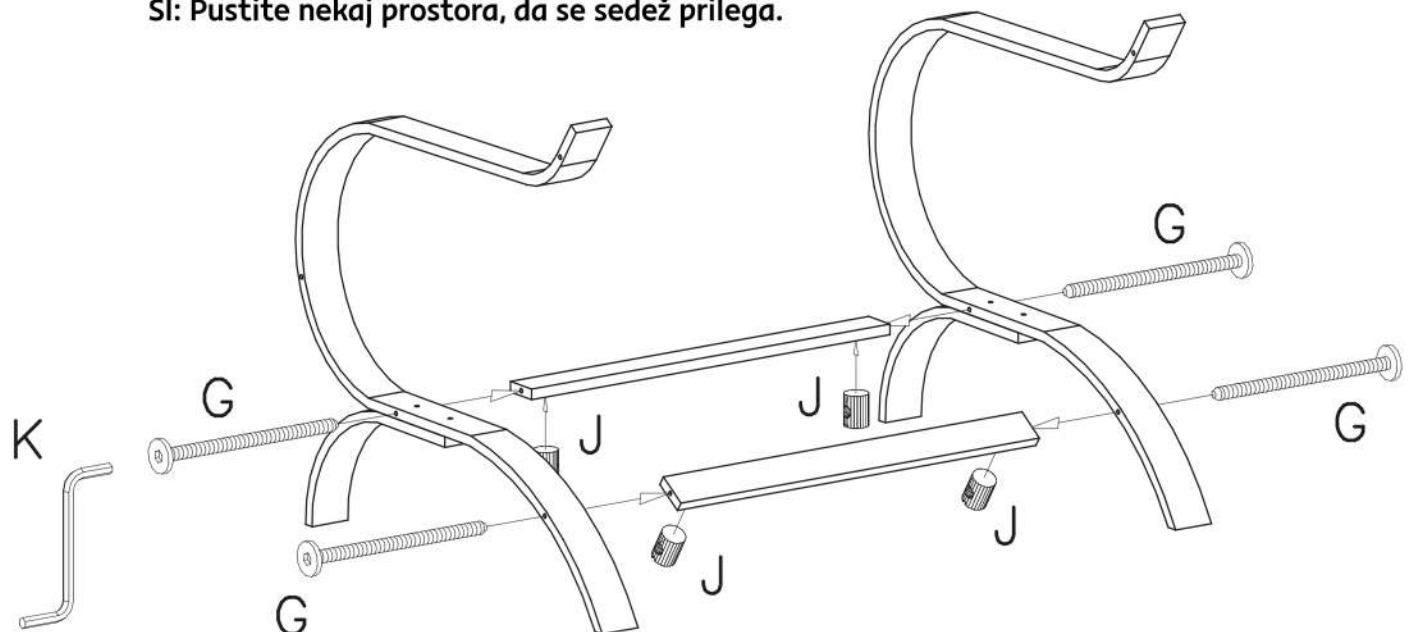

3.

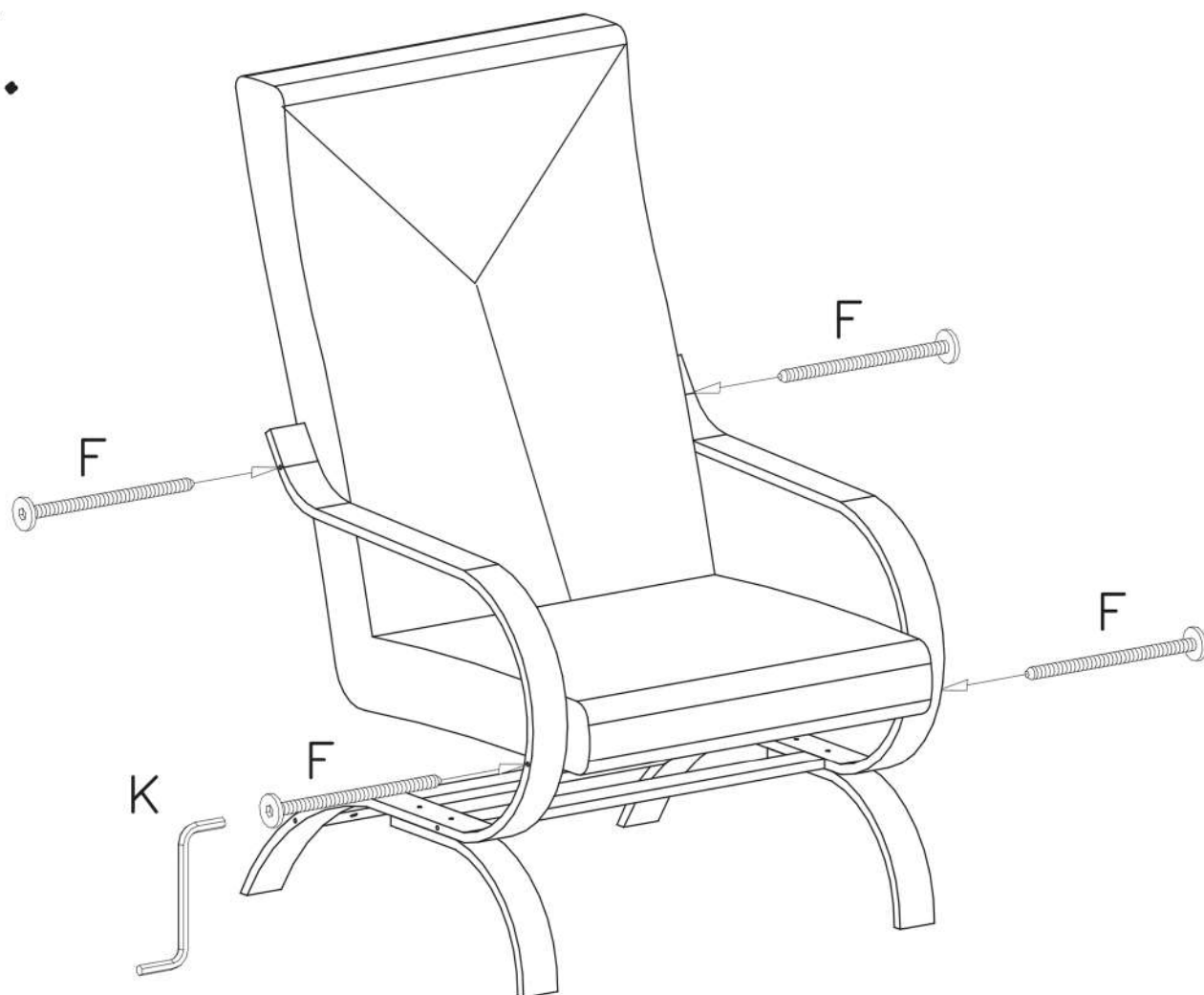

- SK: Dotiahnite všetky skrutky F a G.
CZ: Dotáhněte všechny šrouby F a G.
HU: Húzza meg az összes F és G jelű csavart.
RO: Strângeți toate șuruburile F și G.
HR: Dotegnite sve vijke označene kao F ili G.
SI: Privijte vse vijake F in G.

